

SPACE-RAY
INFRARED GAS HEATERS



INSTALLATION AND OPERATION INSTRUCTIONS

OWNER / INSTALLER: For your safety this manual must be carefully and thoroughly read and understood before installing, operating or servicing this heater.

INFRARED RADIANT TUBE HEATER

Models:

ETU SERIES: (40, 50, 60, 75, 80, 90, 100, 110, 120, 125,
130, 140, 150, 160, 175, 180, 200, 225, 250)

ETS SERIES: (40, 50, 60, 75, 80, 90, 100, 110, 120, 125,
130, 140, 150, 160, 175, 180, 200, 225, 250)

!INSTALLER: This manual is the property of the owner. Please present this manual to the owner when you leave the job site.

▲WARNING: Improper installation, adjustment, alteration, service, or maintenance can cause property damage, injury or death. Read the installation, operation and maintenance instructions thoroughly before installing or servicing this equipment.

!IMPORTANT: SAVE THIS MANUAL FOR FUTURE REFERENCE.

SPACE-RAY

Post Office Box 36485 (28236) • 305 Doggett Street (28203) • Charlotte, North Carolina
Phone (704) 372-3485 • Fax (704) 332-5843 • www.spaceray.com • email: info@spaceray.com

TABLE OF CONTENTS

<u>SECTION</u>	<u>DESCRIPTION</u>	<u>PAGE</u>
1.0)	General Information.....	2
2.0)	ETS/ ETU 40-250 Series — Specifications.....	3
3.0)	ETS/ETU 40-250 Series — Packing List.....	4
4.0)	Accessory Packages.....	11
5.0)	ETS 40-250 Series — Typical Layouts.....	13
6.0)	ETS 180-250 Series — Typical Assembly Layouts.....	14
7.0)	ETU 40-250 Series — Typical Layouts.....	14
7.1)	ETU 180-250 Series — Typical Assembly Layout.....	15
7.2)	ETS 40-250 Series — Dimensions.....	16
7.3)	ETU 40-175 Series — Dimensions.....	17
8.0)	ETS/ETU 40-250 Series — Heater Assembly / Joining of Tube Sections.....	18
8.1)	Assembly of Tube Section.....	20
8.2)	Assembly of Extension Section.....	21
8.3)	Adding Body Reflectors.....	23
8.4)	Joining of Flanged Body Sections.....	24
9.0)	Adding Optional 90° Elbow (ETS Only).....	25
9.1)	Adding Optional Corner Reflector (ETS Only).....	25
10.0)	Adding 180° U-Bend (ETU Only).....	26
10.1)	Adding Optional U-Bend Reflector (ETU Only).....	26
11.0)	Attaching Control Box Assembly.....	27
12.0)	Attaching Draft Inducer Assembly.....	28
13.0)	Multiple Hanging & Draft Inducer Positions — ETS, ETU 40-250.....	29
13.1)	Typical Suspension Methods.....	30
14.0)	Minimum Clearances To Combustibles.....	31
15.0)	Gas Connections And Regulations.....	32
15.1)	Instructions For Pressure Test Gauge Connection.....	33
16.0)	Electrical Connections.....	34
17.0)	Venting.....	35
17.1)	Air For Combustion.....	37
17.2)	Direct Outside Air For Combustion.....	37
18.0)	Lighting And Shutdown Instructions.....	38
19.0)	Ignition System Checks.....	39
20.0)	Sequence Of Operation.....	40
21.0)	Troubleshooting Guide Of Direct Spark Ignition System.....	41
22.0)	Motor And Blower Wheel Check.....	42
23.0)	Cleaning And Annual Maintenance.....	42
24.0)	Replacing Parts.....	42
25.0)	Installation Data.....	42
26.0)	Replacement Parts Guide.....	43

! WHAT TO DO IF YOU SMELL GAS:

- ! Do not try to light any appliance. Extinguish any open flame. Open windows.**
- ! Do not touch any electrical switch; do not use any telephone in your building.**
- ! Immediately call your gas supplier from a neighbor's telephone. Follow the gas supplier's instructions.**
- ! If you cannot reach your gas supplier, call the fire department.**

This heater complies with ANSI Z83.20 (current standard) and CSA 2.34. Copies of the National Fuel Gas Code (ANSI Z223.1-latest edition) are available from the CSA at 8501 East Pleasant Valley Road, Cleveland, Ohio 44131 or 55 Scarsdale Road, Don Mills, Ontario M3B 2R3. All NFPA codes are available from the National Fire Protection Association, Batterymarch Park, Quincy, Massachusetts 02269.

1.0) GENERAL INFORMATION

This heater is a self-contained infrared radiant tube heater for use in locations where flammable gases or vapors are not generally present (as defined by OSHA acceptable limits) and is intended for the heating of **nonresidential** spaces.

INSTALLATION REQUIREMENTS

The installation must conform to local building codes or, in the absence of local codes, with the National Fuel Gas Code ANSI Z223.1/NFPA54 or the Natural Gas and Propane Installation Code CSAB149.1. Heaters shall be installed by a licensed contractor or licensed installer. Clearances to combustibles as outlined in this manual should always be observed. In areas used for storage of combustible materials where they may be stacked below the heater, NFPA54 requires that the installer must post signs that will "specify the maximum permissible stacking height to maintain the required clearances from the heater to combustibles."

The higher capacity ETS/ ETU 180–250 models generate intense radiant heat. Therefore, the minimum recommended mounting height is 18 ft. above floor level for the ETS/ ETU 180-200 models and 20 ft. above floor level for the ETS/ ETU 225-250 models. Heaters may be mounted at various heights and angles depending on the application. If you have any questions, please consult your local Space-Ray representative.

Every heater shall be located with respect to building construction and other equipment so as to permit access to the heater. Each installer shall use quality installation practices when locating the heater and must give consideration to clearances to combustible materials, vehicles parked below, lights, overhead doors, storage areas with stacked materials, sprinkler heads, gas and electrical lines, and any other possible obstructions or hazards. Consideration also must be given to service accessibility.

The heater, when installed in aircraft hangars and public garages, must be installed in accordance with ANSI/NFPA 409-latest edition (Standard for Aircraft Hangars), ANSI/NFPA 88a-latest edition (Standard for Parking Structures), and ANSI/NFPA 88b-latest edition (Standard for Repair Garages) with the following clearances:

- a. At least 10 feet above the upper surfaces of wings or engine enclosures of the highest aircraft that may be housed in the hangar and at least 8 feet above the floor in shops, offices, and other sections of hangars communicating with aircraft storage or service areas.
- b. At least 8 feet above the floor in public garages. **▲WARNING:** Minimum clearances marked on the heater must be maintained from vehicles parked below the heater.

(FOR CANADA ONLY)

- a. Installation of this appliance is to be in accordance with latest edition of CAN 1-B149.1 (Installation Code for Natural Gas Burning Appliances and Equipment), and/or CAN B149.2 (Installation Code for Propane Gas Burning Appliances and Equipment).
- b. For installation in public garages or aircraft hangars, the minimum clearances from the bottom of the infrared heater to the upper surface of the highest aircraft or vehicle shall be 50 percent greater than the certified minimum clearance, but the clearance shall not be less than 8 feet.

Although these heaters may be used in many applications other than space heating (e.g., process heating), Gas-Fired Products, Inc. will not recognize the warranty for any use other than space heating.

This heater is for Indoor Installation and Covered Patio Installation only and can be used in either Vented or Unvented mode. The term Unvented actually means Indirect Vented. While the products of combustion are expelled into the building, national codes require ventilation in the building to dilute these products of combustion. This ventilation may be provided by gravity or mechanical means.

This heater is not an explosion proof heater. Where the possibility of exposure to volatile and low flash point materials exists, it could result in property damage or death. This heater must not be installed in a spray booth where the heater can operate during the spraying process. Consult your local fire marshal or insurance company.

ETS Series Only: Since straight tube heaters are always hotter at the control end than at the draft inducer end, always observe the minimum recommended mounting heights shown on the specification sheets and in Section 2 of this manual. Use U-tube configuration instead of straight tubes for spot or area heating (e.g., where a single heater is utilized for space heating).

▲WARNING: Certain materials or objects, when stored under the heater, will be subjected to radiant heat and could be seriously damaged. Observe the Minimum Clearances to Combustibles listed in the manual and on the heater at all times.

! ATTENTION: SAVE THIS MANUAL FOR FUTURE REFERENCE.

2.0) ETS/ ETU 40-250 SERIES – SPECIFICATIONS

Model No.	Btu/hr Input	Flue Restrictor Plate I.D. & Part #		Orifice Size				Minimum Mounting Height	
				Natural Gas		Propane Gas		@ Horizontal	@ 45° Angle
ETS, ETU 40	40,000	1"	#42741040	#31	(0.120)	#49	(0.073)	10 ft.	9 ft.
ETS, ETU 50	50,000	1-1/8"	#42741030	3.3mm	(0.130)	#46	(0.081)	11 ft.	10 ft.
ETS, ETU 60	60,000	1-7/32"	#42741020	#27	(0.144)	#43	(0.089)	12 ft.	11 ft.
ETS, ETU 75	75,000	1-7/16"	#42741010	#20	(0.161)	#39	(0.099)	13 ft.	12 ft.
ETS, ETU 80	80,000	1-1/2"	#42741050	#19	(0.166)	#38	(0.102)	13 ft.	12 ft.
ETS, ETU 90	90,000	1-1/2"	#42741050	#16	(0.177)	#36	(0.106)	13 ft.	12 ft.
ETS, ETU 100	100,000	1-5/8"	#42741060	#14	(0.182)	#33	(0.113)	13 ft.	12 ft.
ETS, ETU 110	110,000	1-3/4"	#42741070	#10	(0.194)	#31	(0.120)	14 ft.	13 ft.
ETS, ETU 120	120,000	1-3/4"	#42741070	13/64	(0.203)	1/8	(0.125)	14 ft.	13 ft.
ETS, ETU 125	125,000	1-7/8"	#42741080	#5	(0.206)	#30	(0.129)	14 ft.	13 ft.
ETS, ETU 130	130,000	1-7/8"	#42741080	#4	(0.209)	3.3mm	(0.130)	14 ft.	13 ft.
ETS, ETU 140	140,000	2-1/32"	#42741090	5.5mm	(0.216)	#29	(0.136)	15 ft.	14 ft.
ETS, ETU 150	150,000	2-1/32"	#42741090	5.7mm	(0.224)	#28	(0.140)	15 ft.	14 ft.
ETS, ETU 160	160,000	2-1/4"	#42741100	5.8mm	(0.228)	#27	(0.144)	15 ft.	14 ft.
ETS, ETU 175	175,000	2-1/4"	#42741100	"C"	(0.242)	3.8mm	(0.150)	15 ft.	14 ft.
ETS, ETU 180	180,000	2-1/4"	#42741100	"C"	(0.242)	#24	(0.152)	18 ft.	17 ft.
ETS, ETU 200	200,000	2-3/8"	#42741130	"F"	(0.257)	#21	(0.159)	18 ft.	17 ft.
ETS, ETU 225	225,000	2-1/2"	#42741140	6.9mm	(0.272)	#18	(0.170)	20 ft.	19 ft.
ETS, ETU 250	250,000	2-3/4"	#42741150	"K"	(0.281)	4.5mm	(0.177)	20 ft.	19 ft.

* MOUNT HEATERS AS HIGH AS POSSIBLE. Minimums are shown as a guideline for human comfort and uniform energy distribution for complete building heating applications. Consult your Space-Ray representative for the particulars of your installation requirements.

Type Gas:	Gas-Pipe Connection: ¹	Tube Diameter:	Flue Connection: ²	Fresh Air Connection: ²	Electrical Supply:	Current Rating:
Natural or Propane	1/2" NPT (Female)	4"	6" Round	6" Round	120 Volt, 60Hz, 1 Phase	2.6 Amp

NOTES: 1) ETS/ETU200 and above require a minimum 3/4" flex connector.
2) 4" round for models ETS/ETU40-75.

Fuse Rating:		Ignition System:
<i>In-line</i> : 2 Amp 250V (for 24V Circuit)	<i>Spark Module</i> : 3 Amp 250V (for 24V Circuit)	Direct Spark (with 30-second prepurge period)

3.0) ETS/ETU 40-250 SERIES – PACKING LIST

A) ETS/ETU 40-250 Control/Draft Inducer Package	QTY
Control Box Assembly (Refer to the following chart for Package Part Numbers)	1
Draft Inducer & Junction Box Assembly (Refer to Package Part Numbers below)	1
4" x 6" Starting Collar# _# (#42892000).....	1
Control Fastener Kit (#42907110)	1
<i>containing:</i> #8-32 Screws & Nuts (#02127030).....	2
1/4 - 20 Locknuts (#02167010).....	3
Tube Flange Gasket (#42921000)	2
Draft Inducer Flange (#44015251)	1
Installation & Operation Instructions (#43343300).....	1

_ 4-inch Starting Collar (Part #40504020) supplied with ETS/ETU40-75 models.

CONTROL/DRAFT INDUCER PACKAGE NUMBERS:

NATURAL GAS			
MODEL NO	PART NO.	MODEL NO	PART NO.
ETS/U40-N5	#43339010	ETS/U130-N5	#43340130
ETS/U50-N5	#43339030	ETS/U140-N5	#43340150
ETS/U60-N5	#43339050	ETS/U150-N5	#43340170
ETS/U75-N5	#43339070	ETS/U160-N5	#43340190
ETS/U80-N5	#43340010	ETS/U175-N5	#43340210
ETS/U90-N5	#43340030	ETS/U180-N5	#43340230
ETS/U100-N5	#43340050	ETS/U200-N5	#43340250
ETS/U110-N5	#43340070	ETS/U225-N5	#43340270
ETS/U120-N5	#43340090	ETS/U250-N5	#43340290
ETS/U125-N5	#43340110		

PROPANE GAS			
MODEL NO	PART NO.	MODEL NO	PART NO.
ETS/U40-L5	#43339020	ETS/U130-L5	#43340140
ETS/U50-L5	#43339040	ETS/U140-L5	#43340160
ETS/U60-L5	#43339060	ETS/U150-L5	#43340180
ETS/U75-L5	#43339080	ETS/U160-L5	#43340200
ETS/U80-L5	#43340020	ETS/U175-L5	#43340220
ETS/U90-L5	#43340040	ETS/U180-L5	#43340240
ETS/U100-L5	#43340060	ETS/U200-L5	#43340260
ETS/U110-L5	#43340080	ETS/U225-L5	#43340280
ETS/U120-L5	#43340100	ETS/U250-L5	#43340300
ETS/U125-L5	#43340120		

B) ETS 40-175 Body Package Descriptions

(Package Number is indicated on the outside of each corresponding carton.)

		System Lengths	15 Ft System	20Ft System	30 Ft System	40 Ft System	50 System
ETS 40-175 Body Packages – Aluminized/Hot Rolled			15 Ft. Pkg. #44134000	20 Ft. Pkg. #44135000	30 Ft. Pkg. #44136000	40 Ft. Pkg. #44137000	50 Ft. Pkg. #44138000
Part #	Each Body Package Includes:	Qty.	Qty.	Qty.	Qty.	Qty.	Qty.
42912080	10 Ft. Tube with 24 Hole Flange (Aluminized Steel)	1	1	1	1	1	1
41932101	10 Ft. Tube less Flanges (Hot Rolled Steel)	-	1	2	3	4	4
41932051	5 Ft. Tube less Flanges (Hot Rolled Steel)	1	-	-	-	-	-
43319100	Reflector, 9' 11 1/2"	1	2	3	4	5	5
43319050	Reflector, 4' 11 1/2"	1	-	-	-	-	-
30462980	Tube Coupling	1	1	2	3	4	4
43318000	Tube Hanger/Support Bracket, 13"	2	2	3	4	5	5
43980010	Wire Hanger	2	2	3	4	5	5

Body Fastener Kit (included in body packages)		42907190	42907190	42907200	42907210	42907220
42873000	U-Bolt	2	2	3	4	5
02127110	Hex Nut, 5/16-18	5	5	6	8	10
02189020	HWHSM Screw, #10-16 x 1/2" TEKS	8	8	10	14	18
30303010	"S" Hook, size #60	5	5	6	7	8

C) ETS 180-200 Body Package Descriptions

(Package Number is indicated on the outside of each corresponding carton.)

System Lengths

50Ft. System

60Ft. System

ETS 180-200 Body Packages - Aluminized/Hot Rolled		50 Ft. Pkg. #44138020
Part #	Each Body Package Includes:	Qty.
42912080	10 Ft. Tube with 24 Hole Flange (Aluminized Steel)	1
41932100	10 Ft. Tube less Flanges (Aluminized Steel)	1
41932101	10 Ft. Tube less Flanges (Hot Rolled Steel)	3
43319100	Reflector, 9' 11½"	5
30462980	Tube Coupling	4
43318000	Tube Hanger/Support Bracket, 13"	5
43980010	Wire Hanger	5

40 Ft. Pkg. #44137010	20 Ft. Pkg. #44135010
Qty.	Qty.
1	-
1	-
2	2
4	2
3	2
4	2
4	2

Body Fastener Kit (included in body packages)		42907220
42873000	U-Bolt	5
02127110	Hex Nut, 5/16-18	10
02189020	HWHSM Screw, #10-16 x ½" TEKS	18
30303010	"S" Hook, size #60	8

42907210	42907190
4	2
8	5
14	8
7	5

System Lengths

70Ft. System

80Ft. System

ETS 180-200 Body Packages - Aluminized/Hot Rolled		40 Ft. Pkg. #44137010	30 Ft. Pkg. #44136040
Part #	Each Body Package Includes:	Qty.	Qty.
42912080	10 Ft. Tube with 24 Hole Flange (Aluminized Steel)	1	-
41932100	10 Ft. Tube less Flanges (Aluminized Steel)	1	-
41932101	10 Ft. Tube less Flanges (Hot Rolled Steel)	2	3
43319100	Reflector, 9' 11½"	4	3
30462980	Tube Coupling	3	3
43318000	Tube Hanger/Support Bracket, 13"	4	3
43980010	Wire Hanger	4	3

40 Ft. Pkg. #44137010	40 Ft. Pkg. #44137020
Qty.	Qty.
1	-
1	-
2	4
4	4
3	4
4	4
4	4

Body Fastener Kit (included in body packages)		42907210	42907240
42873000	U-Bolt	4	3
02127110	Hex Nut, 5/16-18	8	6
02189020	HWHSM Screw, #10-16 x ½" TEKS	14	10
30303010	"S" Hook, size #60	7	3

42907210	42907210
4	4
8	8
14	14
7	7

D) ETS 225-250 Body Package Descriptions

(Package Number is indicated on the outside of each corresponding carton.)

50Ft. System

60Ft. System

ETS 225-250 Body Packages – Alumi-Therm/Hot Rolled		50 Ft. Pkg. #44138040
Part #	Each Body Package Includes:	Qty.
42912129	10 Ft. Tube with (2) 6 Hole Flanges (Alumi-Therm Steel)	1
42912099	10 Ft. Tube with 6 Hole Flange (Alumi-Therm Steel)	1
41932101	10 Ft. Tube less Flanges (Hot Rolled Steel)	3
43319100	Reflector, 9' 11½"	5
30462980	Tube Coupling	3
43318000	Tube Hanger/Support Bracket, 13"	5
43980010	Wire Hanger	5
42907080	Tube Flange Fasteners (includes (6) ¼-20 screws/nuts)	1
42921000	Tube Flange Gasket	1

40 Ft. Pkg. #44137030	20 Ft. Pkg. #44135010
Qty.	Qty.
1	-
1	-
2	2
4	2
2	2
4	2
4	2
1	-
1	-

Body Fastener Kit (included in body packages)		42907220
42873000	U-Bolt	5
02127110	Hex Nut, 5/16-18	10
02189020	HWHSM Screw, #10-16 x ½" TEKS	18
30303010	"S" Hook, size #60	8

42907210	42907190
4	2
8	5
14	8
7	5

System Lengths

70Ft. System

80Ft. System

ETS 225-250 Body Packages – Alumi-Therm/Hot Rolled		40 Ft. Pkg. #44137030	30 Ft. Pkg. #44136040
Part #	Each Body Package Includes:	Qty.	Qty.
42912129	10 Ft. Tube with (2) 6 Hole Flanges (Alumi-Therm Steel)	1	-
42912099	10 Ft. Tube with 6 Hole Flange (Alumi-Therm Steel)	1	-
41932101	10 Ft. Tube less Flanges (Hot Rolled Steel)	2	3
43319100	Reflector, 9' 11½"	4	3
30462980	Tube Coupling	2	3
43318000	Tube Hanger/Support Bracket, 13"	4	3
43980010	Wire Hanger	4	3
42907080	Tube Flange Fasteners (includes (6) ¼-20 screws/nuts)	1	-
42921000	Tube Flange Gasket	1	-

40 Ft. Pkg. #44137030	40 Ft. Pkg. #44137020
Qty.	Qty.
1	-
1	-
2	4
4	4
2	4
4	4
4	4
1	-
1	-

Body Fastener Kit (included in body packages)		42907210	42907200
42873000	U-Bolt	4	3
02127110	Hex Nut, 5/16-18	8	6
02189020	HWHSM Screw, #10-16 x ½" TEKS	14	10
30303010	"S" Hook, size #60	7	6

42907210	42907210
4	4
8	8
14	14
7	7

E) ETS 40-175 Series Body Package Descriptions – ALC Option (Aluminized Calorized)

(Package Part Number is indicated on the outside of carton.)

System Lengths

ETS 40-175 Body Packages – ALC -Aluminized		15 Ft. Pkg. #44134010	20 Ft. Pkg. #44135020	30 Ft. Pkg. #44136020	40 Ft. Pkg. #44137040	50 Ft. Pkg. #44138060
Part #	Each Body Package Includes:	Qty.	Qty.	Qty.	Qty.	Qty.
42912080	10 Ft. Tube with 24 Hole Flange (Aluminized)	1	1	1	1	1
41932100	10 Ft. Tube less Flanges (Aluminized)	-	1	2	3	4
41932050	5 Ft. Tube less Flanges (Aluminized)	1	-	-	-	-
43319100	Reflector, 9' 11½"	1	2	3	4	5
43319050	Reflector, 4' 11 ½"	1	-	-	-	-
30462980	Tube Coupling	1	1	2	3	4
43318000	Tube Hanger/Support Bracket, 13"	2	2	3	4	5
43980010	Wire Hanger	2	2	3	4	5

Body Fastener Kit (included in body packages)		#42907190	#42907190	#42907200	#42907210	#42907220
42873000	U-Bolt	2	2	3	4	5
02127110	Hex Nut, 5/16-18	5	5	6	8	10
02189020	HWHSM Screw, #10-16 x ½" TEKS	8	8	10	14	18
30303010	"S" Hook, size #60	5	5	6	7	8

F) ETU 40-175 Body Package Descriptions

(Package Number is indicated on the outside of each corresponding carton.)

System Lengths

		20Ft System	30 Ft System	40 Ft System	50 Ft System
ETU 40-175 Body Packages – Aluminized/Hot Rolled		20 Ft. Pkg. #44135000	30 Ft. Pkg. #44136010	40 Ft. Pkg. #44137000	50 Ft. Pkg. #44138010
Part #	Each Body Package Includes:	Qty.	Qty.	Qty.	Qty.
42912080	10 Ft. Tube with 24 Hole Flange (Aluminized Steel)	1	1	1	1
41932101	10 Ft. Tube less Flanges (Hot Rolled Steel)	1	1	3	3
41932051	5 Ft. Tube less Flanges (Hot Rolled Steel)	-	2	-	2
43319100	Reflector, 9' 11½"	2	2	4	4
43319050	Reflector, 4' 11 ½"	-	2	-	2
30462980	Tube Coupling	1	3	3	5
43318000	Tube Hanger/Support Bracket, 13"	2	4	4	6
43980010	Wire Hanger	2	4	4	6

Body Fastener Kit (included in body packages)		42907190	42907210	42907210	42907221
42873000	U-Bolt	2	4	4	5
02127110	Hex Nut, 5/16-18	5	8	8	10
02189020	HWHSM Screw, #10-16 x ½" TEKS	8	14	14	18
30303010	"S" Hook, size #60	5	7	7	8

U-Bend Package		43208020	43208020	43208020	43208020
42873000	U-Bend	1	1	1	1
43318500	31" Tube Support/Hanger Bracket	1	1	1	1
30462980	Tube Coupling	1	1	1	1
02189020	HWHSM Screw, #10-16 x ½" TEKS	2	2	2	2

G) ETU 180-200 Body Package Descriptions

(Package Number is indicated on the outside of each corresponding carton.)

System Lengths		50Ft. System	60Ft. System	
ETU 180-200 Body Packages - Aluminized/Hot Rolled		50 Ft. Pkg. #44138030	40 Ft. Pkg. #44137010	20 Ft. Pkg. #44135010
Part #	Each Body Package Includes:	Qty.	Qty.	Qty.
42912080	10 Ft. Tube with 24 Hole Flange (Aluminized Steel)	1	1	-
41932100	10 Ft. Tube less Flanges (Aluminized Steel)	1	1	-
41932101	10 Ft. Tube less Flanges (Hot Rolled Steel)	2	2	2
41932051	5 Ft. Tube less Flanges (Hot Rolled Steel)	2	-	-
43319100	Reflector, 9' 11½"	4	4	2
43319050	Reflector, 4' 11 ½'	2	-	-
30462980	Tube Coupling	5	3	2
43318000	Tube Hanger/Support Bracket, 13"	6	4	2
43980010	Wire Hanger	6	4	2

Body Fastener Kit (included in body packages)		42907221	42907210	42907190
42873000	U-Bolt	6	4	2
02127110	Hex Nut, 5/16-18	13	8	5
02189020	HWHSM Screw, #10-16 x ½" TEKS	24	14	8
30303010	"S" Hook, size #60	9	7	5

System Lengths		70Ft. System		80Ft. System	
ETU 180-200 Body Packages - Aluminized/Hot Rolled		40 Ft. Pkg. #44137050	30 Ft. Pkg. #44136040	40 Ft. Pkg. #44137010	40 Ft. Pkg. #44137020
Part #	Each Body Package Includes:	Qty.	Qty.	Qty.	Qty.
42912080	10 Ft. Tube with 24 Hole Flange (Aluminized Steel)	1	-	1	-
41932100	10 Ft. Tube less Flanges (Aluminized Steel)	1	-	1	-
41932101	10 Ft. Tube less Flanges (Hot Rolled Steel)	1	3	2	4
41932051	5 Ft. Tube less Flanges (Hot Rolled Steel)	2	-	-	-
43319100	Reflector, 9' 11½"	3	3	4	4
43319050	Reflector, 4' 11 ½"	2	-	-	-
30462980	Tube Coupling	4	3	3	4
43318000	Tube Hanger/Support Bracket, 13"	5	3	4	4
43980010	Wire Hanger	5	3	4	4

Body Fastener Kit (included in body packages)		42907220	42907200	42907210	42907210
42873000	U-Bolt	5	3	4	4
02127110	Hex Nut, 5/16-18	10	6	8	8
02189020	HWHSM Screw, #10-16 x ½" TEKS	18	10	14	14
30303010	"S" Hook, size #60	8	6	7	7

U-Bend Package		43208020	43208020	43208020	43208020
42873000	U-Bend	1	1	1	1
43318500	31" Tube Support/Hanger Bracket	1	1	1	1
30462980	Tube Coupling	1	1	1	1
02189020	HWHSM Screw, #10-16 x ½" TEKS	2	2	2	2

H) ETU 225-250 Body Package Descriptions

(Package Number is indicated on the outside of each corresponding carton.)

System Lengths		50Ft. System	
ETU 225-250 Body Packages - Alumi-Therm/Hot Rolled		50 Ft. Pkg. #44138050	
Part #	Each Body Package Includes:	Qty.	
42912129	10 Ft. Tube with (2) 6 Hole Flanges (Alumi-Therm Steel)	1	
42912099	10 Ft. Tube with 6 Hole Flange (Alumi-Therm Steel)	1	
41932101	10 Ft. Tube less Flanges (Hot Rolled Steel)	2	
41932051	5 Ft. Tube less Flanges (Hot Rolled Steel)	2	
43319100	Reflector, 9' 11½"	4	
43319050	Reflector, 4' 11 ½"	2	
30462980	Tube Coupling	4	
43318000	Tube Hanger/Support Bracket, 13"	6	
43980010	Wire Hanger	6	
42907080	Tube Flange Fasteners (includes (6) ¼-20 screws/nuts)	1	
42921000	Tube Flange Gasket	1	

60Ft. System	
40 Ft. Pkg. #44137030	20 Ft. Pkg. #44135010
Qty.	Qty.
1	-
1	-
2	2
-	-
4	2
-	-
2	2
4	2
4	2
1	-
1	-

Body Fastener Kit (included in body packages)		42907221
42873000	U-Bolt	6
02127110	Hex Nut, 5/16-18	13
02189020	HWHSM Screw, #10-16 x ½" TEKS	24
30303010	"S" Hook, size #60	9

42907210	42907190
4	2
8	5
14	8
7	5

U-Bend Package		43208020
42873000	U-Bend	1
43318500	31" Tube Support/Hanger Bracket	1
30462980	Tube Coupling	1
02189020	HWHSM Screw, #10-16 x ½" TEKS	2

43208020	43208020
1	1
1	1
1	1
2	2

System Lengths		70Ft. System	
ETU 225-250 Body Packages - Alumi-Therm/Hot Rolled		40 Ft. Pkg. #44137060	30 Ft. Pkg. #4413604
Part #	Each Body Package Includes:	Qty.	Qty.
42912129	10 Ft. Tube with (2) 6 Hole Flanges (Alumi-Therm Steel)	1	-
42912099	10 Ft. Tube with 6 Hole Flange (Alumi-Therm Steel)	1	-
41932101	10 Ft. Tube less Flanges (Hot Rolled Steel)	1	3
41932051	5 Ft. Tube less Flanges (Hot Rolled Steel)	2	-
43319100	Reflector, 9' 11½"	3	3
43319050	Reflector, 4' 11 ½"	2	-
30462980	Tube Coupling	3	3
43318000	Tube Hanger/Support Bracket, 13"	5	3
43980010	Wire Hanger	5	3
42907080	Tube Flange Fasteners (includes (6) ¼-20 screws/nuts)	1	-
42921000	Tube Flange Gasket	1	-

80Ft. System	
40 Ft. Pkg. #44137030	40 Ft. Pkg. #44137020
Qty.	Qty.
1	-
1	-
2	4
-	-
4	4
-	-
2	4
4	4
4	4
1	-
1	-

H) ETU 225-250 Body Package Descriptions - continued

(Package Number is indicated on the outside of each corresponding carton.)

System Lengths		70Ft. System		80Ft. System	
Body Fastener Kit (included in body packages)		42907220	42907200	42907210	42907210
42873000	U-Bolt	5	3	4	4
02127110	Hex Nut, 5/16-18	10	6	8	8
02189020	HWHSM Screw, #10-16 x 1/2" TEKS	18	10	14	14
30303010	"S" Hook, size #60	8	6	7	7
U-Bend Package		43208020	43208020	43208020	43208020
42873000	U-Bend	1	1	1	1
43318500	31" Tube Support/Hanger Bracket	1	1	1	1
30462980	Tube Coupling	1	1	1	1
02189020	HWHSM Screw, #10-16 x 1/2" TEKS	2	2	2	2

I) ETU 40-175 Series Body Package Descriptions ALC Option (Aluminized Calorized)

(Package Part Number is indicated on the outside of each corresponding carton.)

System Lengths		20 Ft. Pkg. #44135020	30 Ft. Pkg. #44136030	40 Ft. Pkg. #44137040	50 Ft. Pkg. #44138070
ETU 40-175 Body Packages - Aluminized					
Part #	Each Body Package Includes:	Qty.	Qty.	Qty.	Qty.
42912080	10 Ft. Tube with 24 Hole Flange (Aluminized)	1	1	1	1
41932100	10 Ft. Tube less Flanges (Aluminized)	1	1	3	3
41932050	5 Ft. Tube less Flanges (Aluminized)	-	2	-	2
43319100	Reflector, 9' 11 1/2"	2	2	4	4
43319050	Reflector, 4' 11 1/2"	-	2	-	2
30462980	Tube Coupling	1	3	3	5
43318000	Tube Hanger/Support Bracket, 13"	2	4	4	6
43980010	Wire Hanger	2	4	4	6
Body Fastener Kit (included in body packages)		#42907190	#42907210	#42907210	#42907221
42873000	U-Bolt	2	4	4	5
02127110	Hex Nut, 5/16-18	5	8	8	10
02189020	HWHSM Screw, #10-16 x 1/2" TEKS	8	14	14	18
30303010	"S" Hook, size #60	5	7	7	8
U-Bend Package		#43208040	#43208040	#43208040	#43208040
42873000	U-Bend	1	1	1	1
43318500	31" Tube Support/Hanger Bracket	1	1	1	1
30462980	Tube Coupling	1	1	1	1
02189020	HWHSM Screw, #10-16 x 1/2" TEKS	2	2	2	2

4.0) ACCESSORY PACKAGES

A) End Reflector Accessory Package, Part #43341010 (1 pkg. per ETS Series or 2 pkgs. per ETU Series)

Contains:

End Reflector, #43320000.....QTY-2

Speed Clips, #02266010.....QTY-8

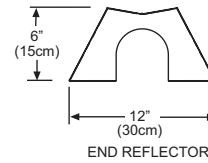

B) Elbow Accessory Package, Part #43208010 (Option for ETS Series Only)

Contains:

Elbow, #431750010.....QTY-1

#10-16 x 1/2 Self-Drilling Screws, #02189020.....QTY-2

Tube Coupling, #30462980.....QTY-1

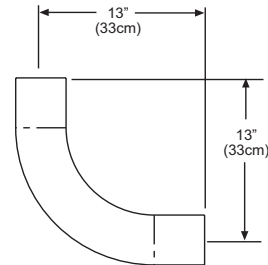

C) Corner Reflector Accessory Package, Part #43342000 (Option for ETS Series Only)

Contains:

Corner Reflector Assembly, #43345000.....QTY-1

Speed Clips, #02266010.....QTY-4

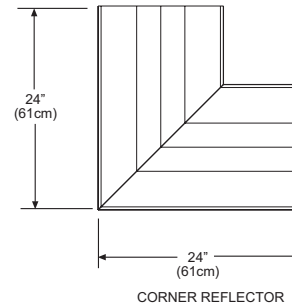

D) U-Bend Package, Part #43208020 (Option for ETU Series Only)

Contains:

U-Bend, #42913020.....QTY-1

#10-16 x 1/2 Self-Drilling Screws, #02189020.....QTY-2

Tube Coupling, #30462980.....QTY-1

31" Hanger/Tube Support, #43318500.....QTY-1

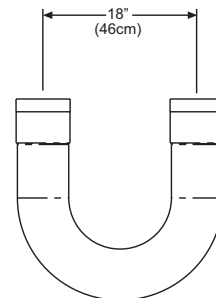

E) U-Bend Reflector Package, Part #43488000 (Option for ETU Series Only)

Contains:

U-Bend Reflector, #43490000.....QTY-1

U-Bend End Reflector, #43490050.....QTY-1

Speed Clips, #02266010.....QTY-11

#10-16 x 1/2 Self-Drilling Screws, #02189020.....QTY-4

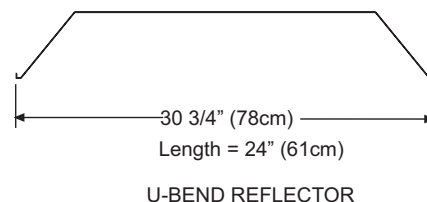

F) 31" Hanger/Tube Support, Part #4331850
(Option for Angle Mounting of ETU Series)

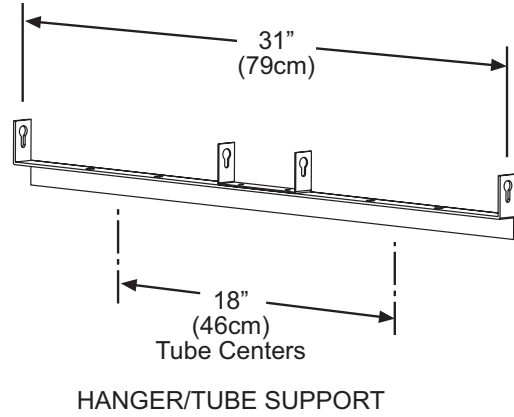

G) Exhaust Hood Package, Part #42924000

Contains:

Exhaust Hood Assembly, #42925540.....QTY-1
 #10-16 x 1/2 Self-Drilling Screws, #02189020.....QTY-2

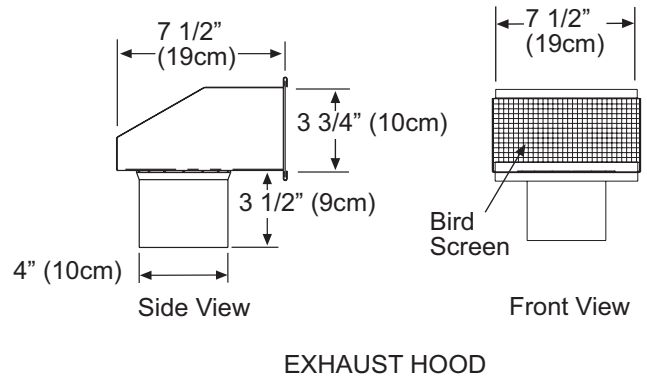

5.0) ETS 40-250 SERIES — TYPICAL LAYOUTS

- Straight U Shape
 L Shape Z Shape

MODEL	EMITTER LENGTH	
	Min.	Max.
ETS 40	15 Ft.	20 Ft.
ETS 50	15 Ft.	30 Ft.
ETS 60	20 Ft.	30 Ft.
ETS 75	20 Ft.	30 Ft.
ETS 80	30 Ft.	40 Ft.
ETS 90	30 Ft.	40 Ft.
ETS 100	30 Ft.	40 Ft.
ETS 110	30 Ft.	40 Ft.
ETS 120	30 Ft.	40 Ft.
ETS 125	30 Ft.	50 Ft.
ETS 130	30 Ft.	50 Ft.
ETS 140	40 Ft.	50 Ft.
ETS 150	40 Ft.	50 Ft.
ETS 160	40 Ft.	50 Ft.
ETS 175	40 Ft.	50 Ft.
ETS 180	50 Ft.	80 Ft.
ETS 200	50 Ft.	80 Ft.
ETS 225	50 Ft.	80 Ft.
ETS 250	50 Ft.	80 Ft.

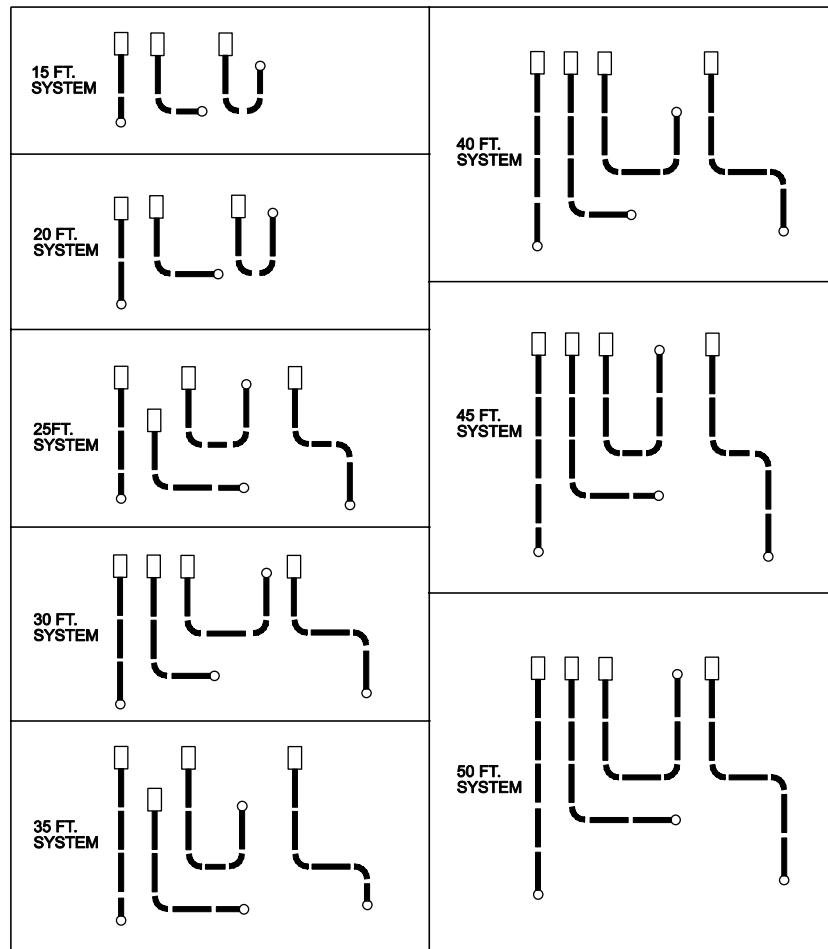

LEGEND

- Control Unit
- Draft Inducer Unit
- 10 FT. Body Section
- 5 FT. Body Section
- 90 Deg. Elbow

TYPICAL LAYOUTS UP TO 50FT. ARE SHOWN

NOTES:

- In all configurations, the control unit must be connected directly to either **a)** the 24-hole flange of the 10 ft. aluminized steel start/end body section (for ETS 40-200 models) **or b)** the 6-hole flange of the 10 ft. Alumi-Therm starting body section (for ETS/ETU 225 and 250 models). **Failure to attach the control box to the 6-hole flange for ETS/ETU 225-250 as indicated above will void the manufacturer's warranty.**
- Joining of two 90° elbows directly together to form a "Z" shape IS NOT permitted.
- 5 Ft. Body Packages may be utilized on any of these heaters to yield heater lengths from 15 ft. to 80 ft.
- Any configuration of components not shown in the illustrations may be used except as noted in 1 and 2 above.

6.0) ETS 180-250 SERIES — TYPICAL ASSEMBLY LAYOUT

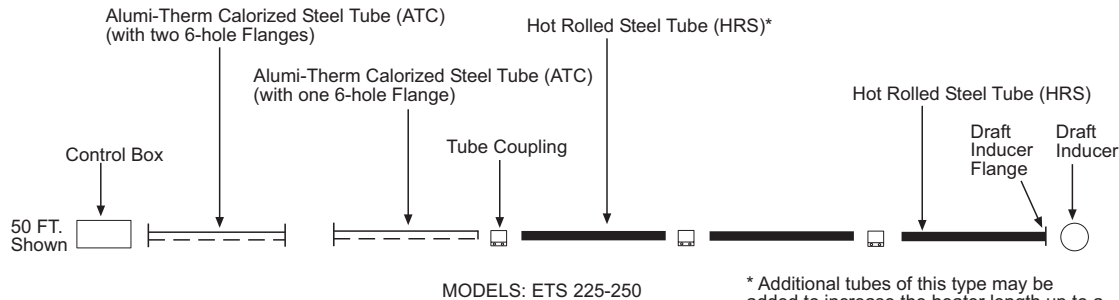
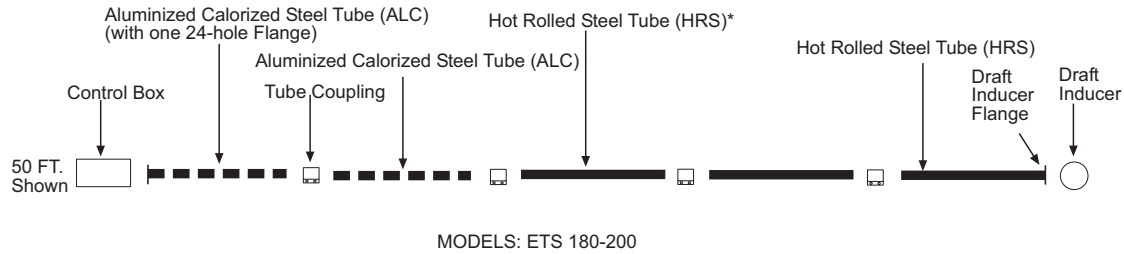

7.0) ETU 40-250

BODY LENGTH ^W	TOTAL EMITTER LENGTH	MODELS
10 Ft.	20 Ft.	ETU 40, 50, 60, 75
15 Ft.	30 Ft.	ETU 50, 60, 75, 80, 90, 100, 110, 120, 125, 130
20 Ft.	40 Ft.	ETU 80, 90, 100, 110, 120, 125, 130, 140, 150, 160, 175
25 Ft.	50 Ft.	ETU 125, 130, 140, 150, 160, 175
25 Ft.	50 Ft.	ETU 180, 200, 225, 250
30 Ft.	60 Ft.	ETU 180, 200, 225, 250
35 Ft.	70 Ft.	ETU 180, 200, 225, 250
40 Ft.	80 Ft.	ETU 180, 200, 225, 250

^W Plus U-Bend

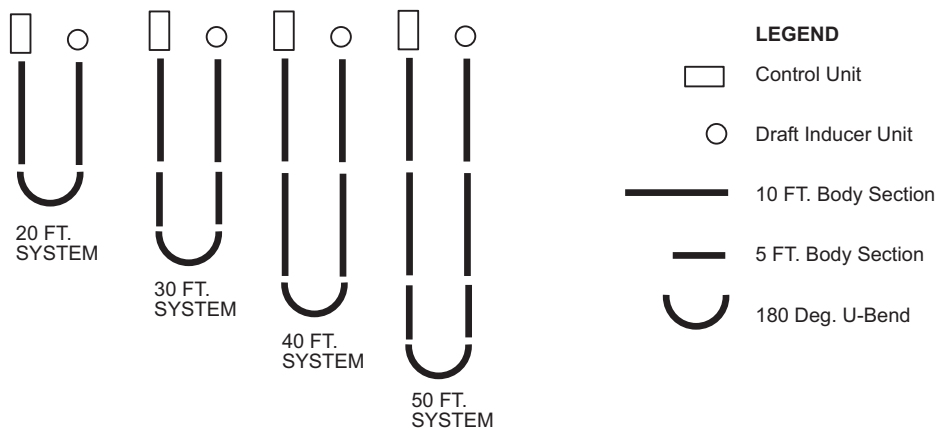

TYPICAL LAYOUTS UP TO 50FT. ARE SHOWN

7.1) ETU 180-250 SERIES — TYPICAL ASSEMBLY LAYOUT

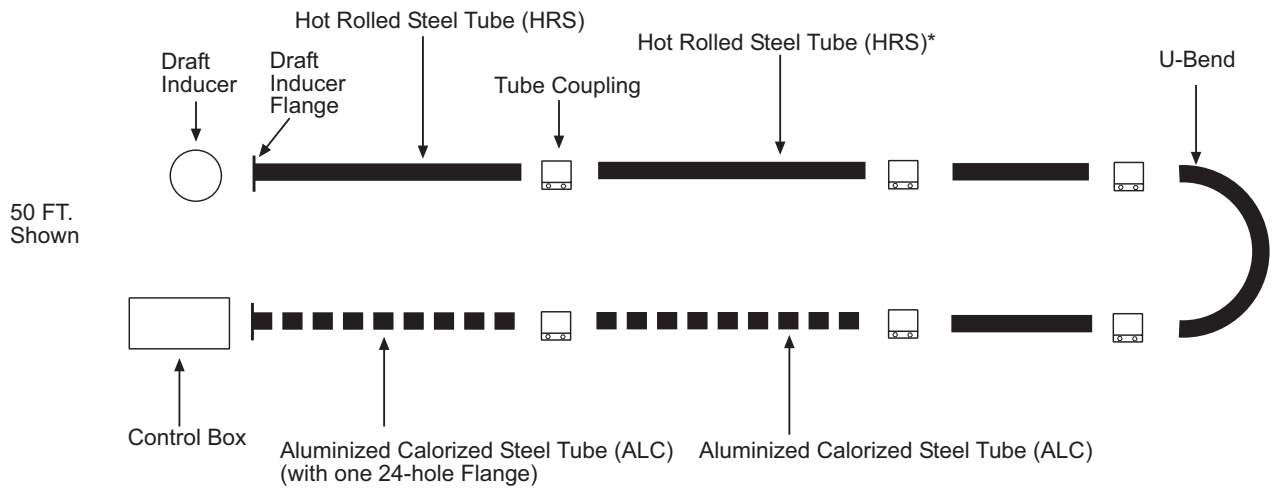

MODELS: ETU 180-200

* Additional tubes of this type may be added to increase the heater length up to a maximum of 80 ft.

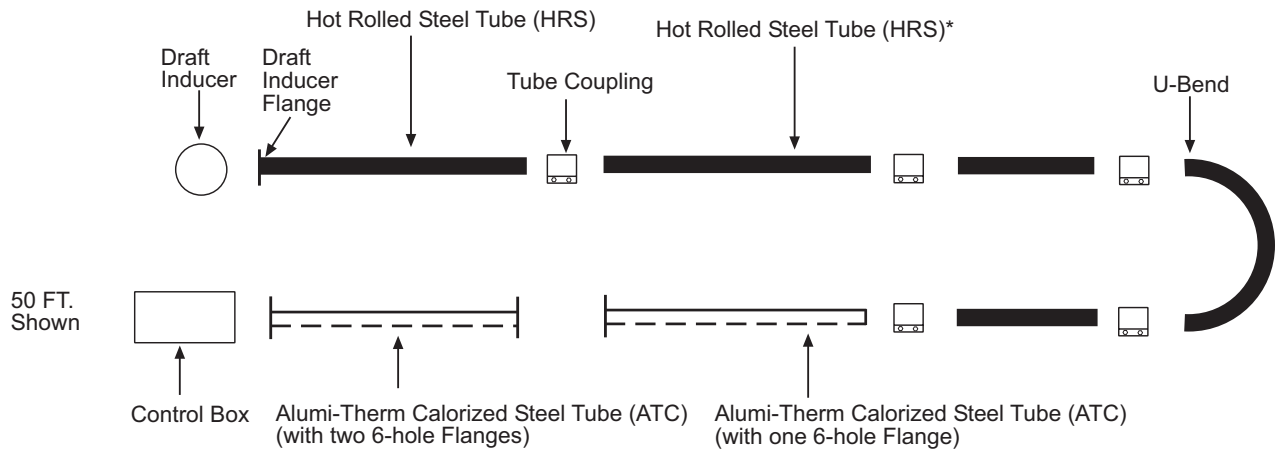

MODELS: ETU 225-250

* Additional tubes of this type may be added to increase the heater length up to a maximum of 80 ft.

7.2) ETS 40-250 SERIES — DIMENSIONS

Typical Dimensions up to 50 Ft Shown,

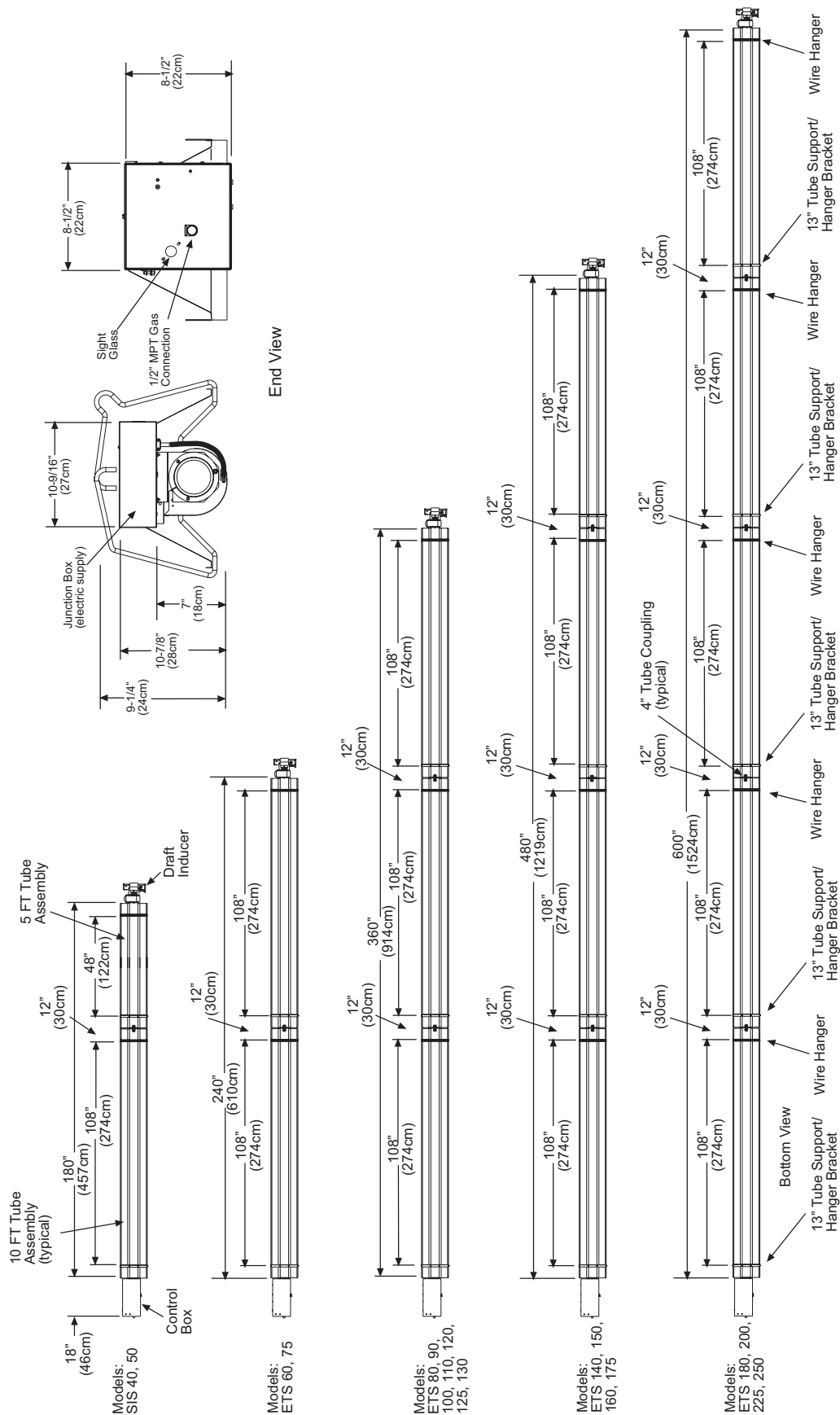

7.3) ETU 40-250 SERIES – DIMENSIONS

Typical Dimensions up to 50 Ft Shown,

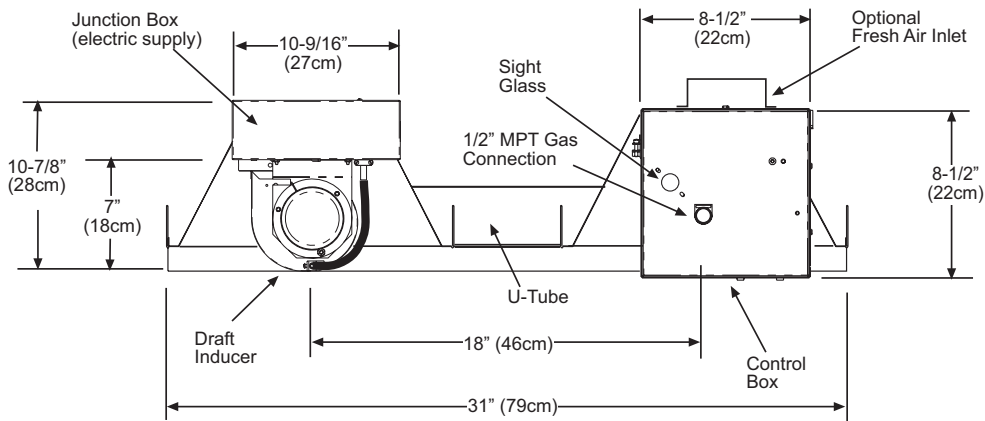
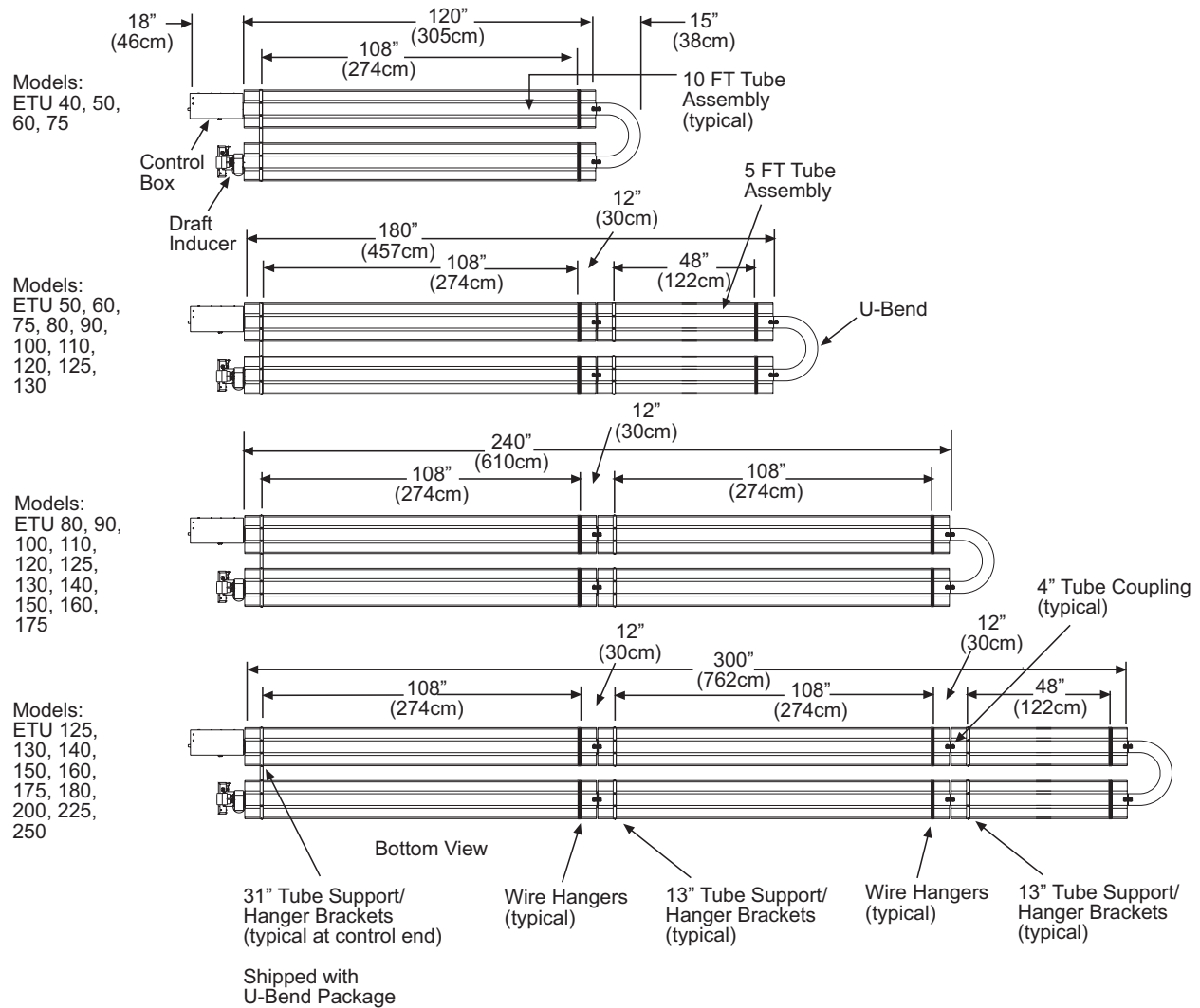

ETU (end view)

8.0) ETS/ETU SERIES - HEATER ASSEMBLY/JOINING OF TUBE SECTIONS

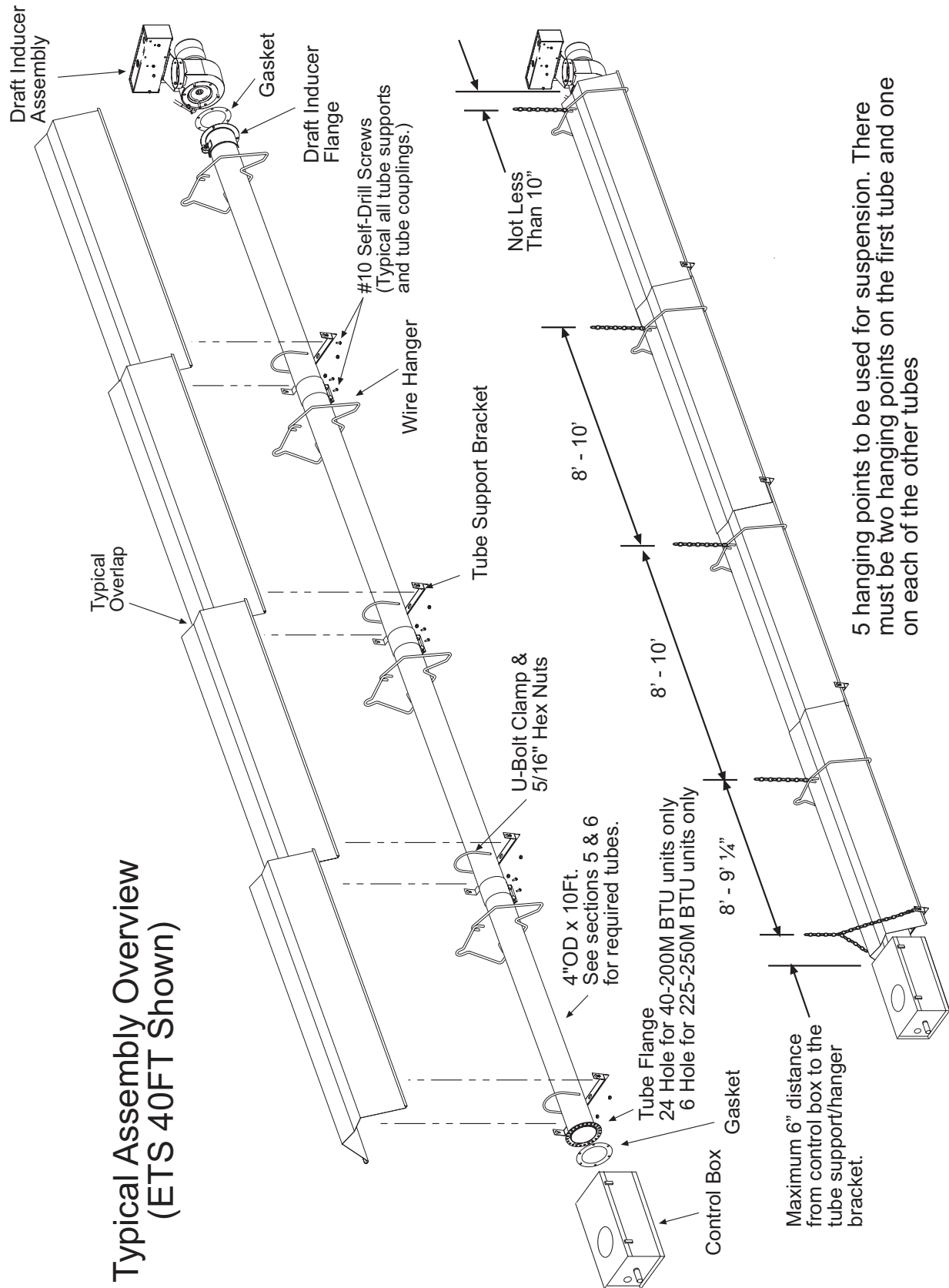

Typical Assembly Overview (ETU 40FT Shown)

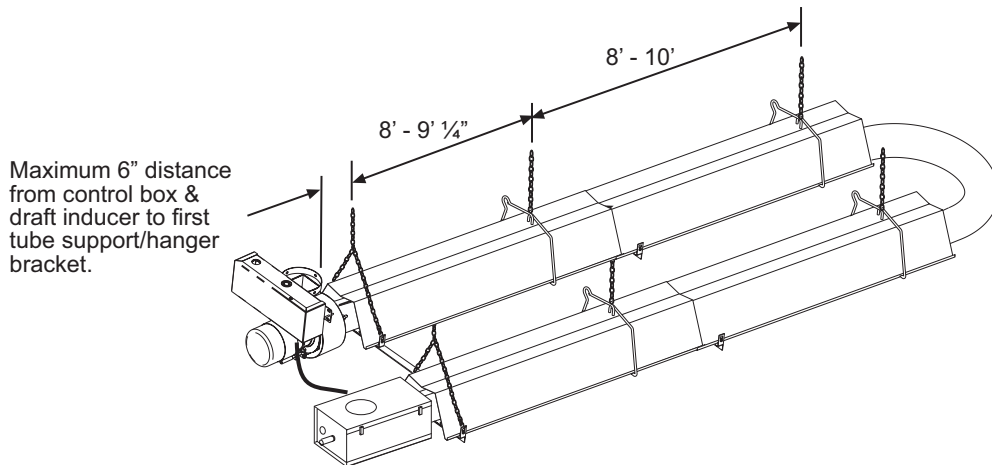
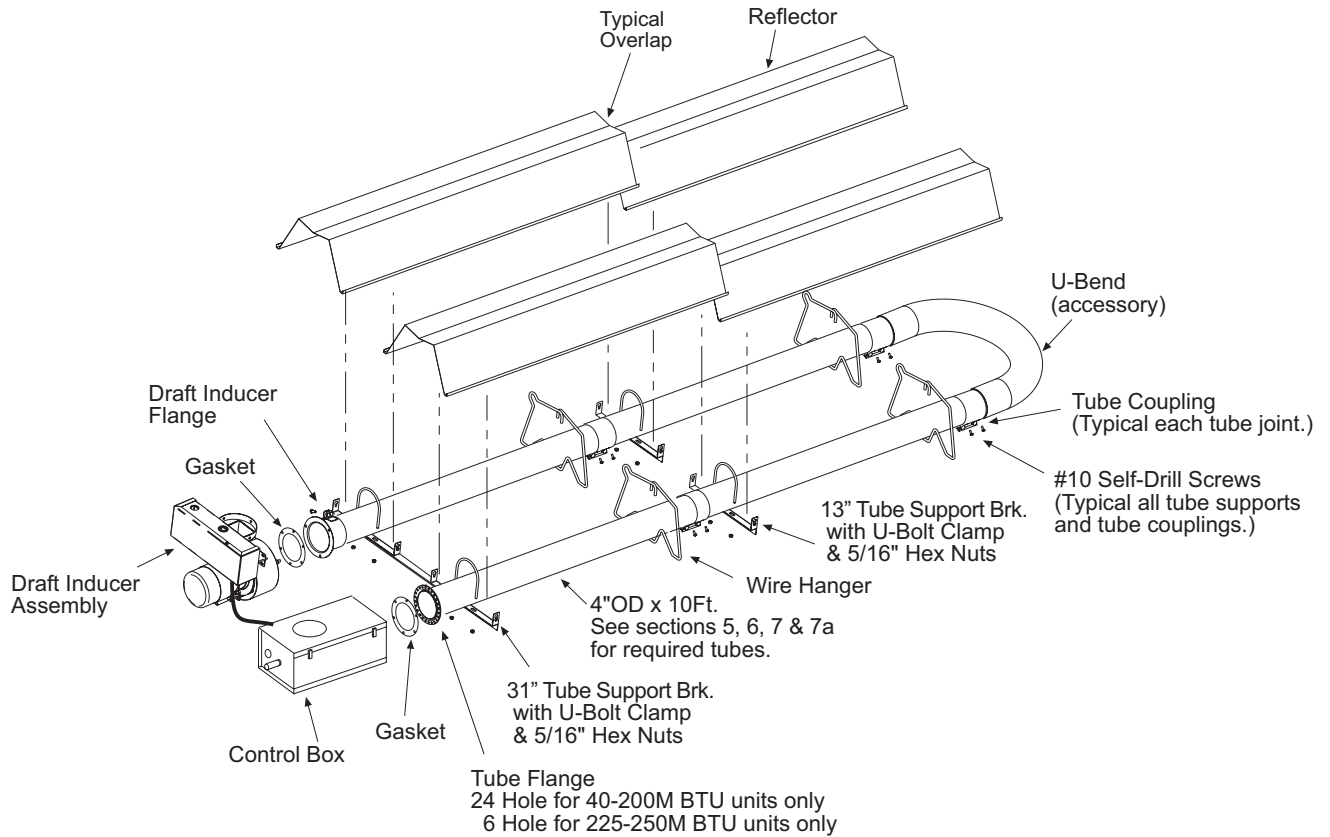

6 hanging points to be used for suspension. There must be two hanging points on the first tube and one on each of the other tubes

8.1) ASSEMBLY OF TUBE SECTIONS

During field assembly of the heater body sections, the recommended procedure is as follows:

1. Before hanging heater sections, first determine the actual layout of the system (see Sections 5 & 7 for details). Consideration must also be taken for flue pipe, fresh air ducting, gas piping, etc. before hanging heater. Typical suspension methods are shown in Section 13.1.
2. Hang each tube section individually. **DO NOT** attach the heater tube sections together on the ground and attempt to hang the entire system.
3. The first 10' tube section must be either aluminized steel (40-200 MBtu/hr models with 24-hole flange) or Alumi-Therm (225-250 MBtu/hr models with 6-hole flanges) as the primary heat exchanger and the control box connected directly to these tube sections. **Failure to attach the control box to the flange end as indicated above will void the manufacturer's warranty.**
4. Place a tube support/hanger bracket on the end of the heat exchanger tube having the mounting flange. Align the tube such that the welded seam is facing down toward the ground. **FAILURE TO ASSEMBLE THE TUBE WITH THE SEAM FACING DOWN WILL VOID THE MANUFACTURER'S WARRANTY.**
5. Space the tube support/hanger bracket 6 inches from center of its slotted holes to the front face of the mounting flange. Secure the tube to the support/hanger bracket using a "U" Bolt clamp and two (2) 5/16-18 nuts provided. For U-tube configuration, see typical assembly overview illustration in Section 8.0
6. Suspend the chain to attach the wire hanger and the tube support bracket. Insert the tube into the wire hanger and then raise the tube support bracket end up to the suspension chain, use "S" hooks to attach the wire hanger and tube support bracket to the chain. See Section 13.1 for typical suspension methods.

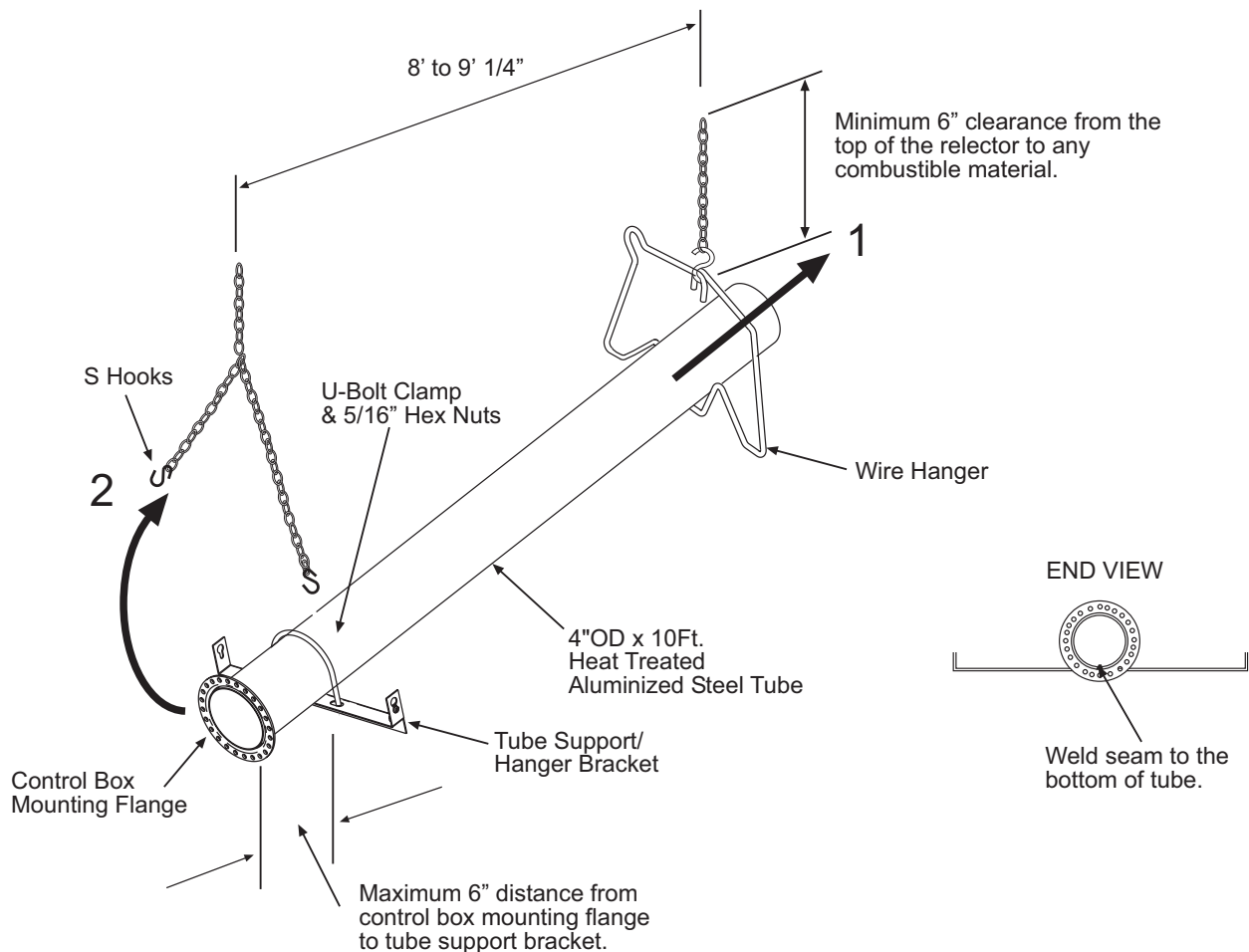

8.2) ASSEMBLY OF EXTENSION SECTION

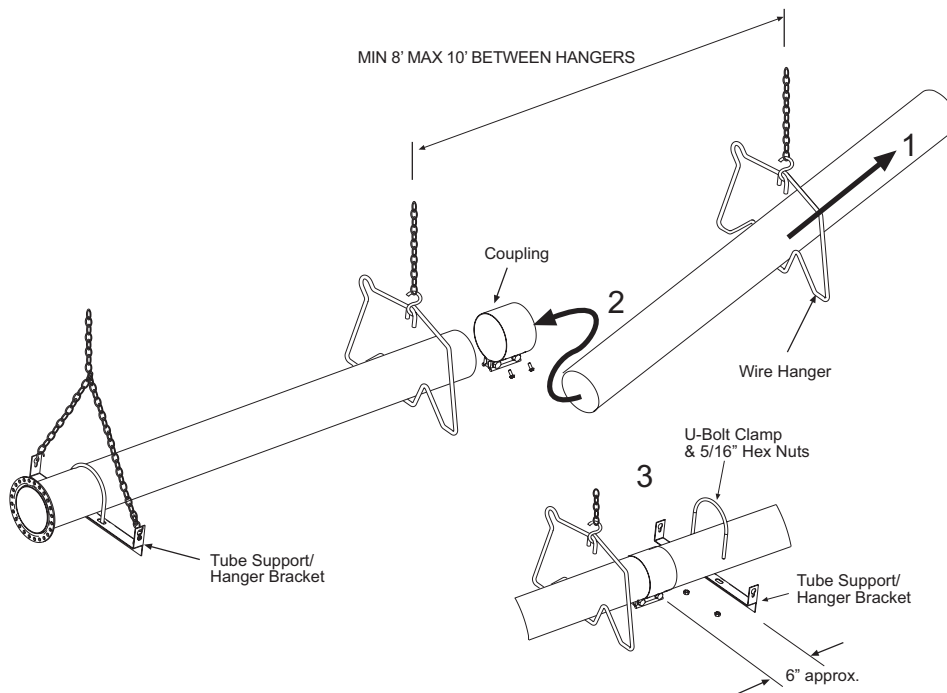

1. Join the body sections together and secure with tube couplings as described below:

▲WARNING: THE FOLLOWING COUPLING TIGHTENING INSTRUCTIONS MUST BE FOLLOWED PROPERLY TO AVOID FUTURE PROBLEMS.

- a. Place the compression coupling over the end of the tube from one body section, with the tightening bolts located on the bottom and facing the installer. **NOTE:** There is a small hole at the centerline of the coupling that can be used to sight the end of the tube.
- b. Partially tighten the bolt nearest the end of the tube (approximately half closed).
- c. Slide the ends of tube from the opposite body section into the coupling. Make sure both tube ends are butted together.
- d. Finish tightening both bolts to 40-60 ft.lbs. torque to ensure a complete seal.
- e. Check to ensure that the hardware is completely closed and the band is seated on the reaction block and interference pins as illustrated below.
- f. Check to see if the reaction block is firmly seated on the tube.
- g. Self-drilling screws are provided to prevent any possible movement of tubes from the coupling. Install the screws as shown using an electric or air screwdriver with approximately 2500 rpm speed. Pre-punched holes in the coupling make it easier to install these self-drilling screws.
- h. Once all the heater body sections are attached, make sure that the heater system is level. If it is not, slight adjustments can be made using the turnbuckles. (See Section 13.1)

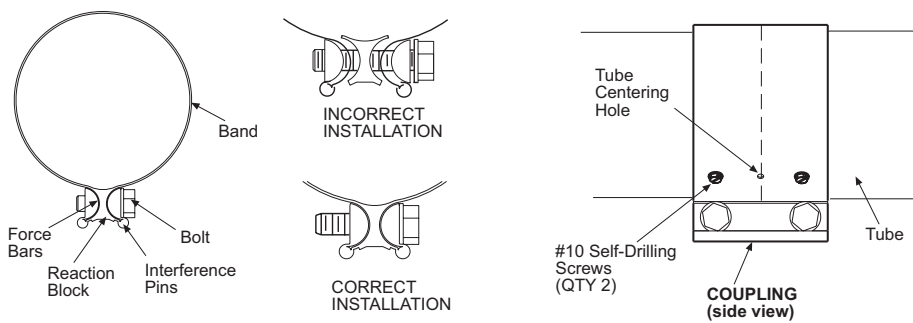
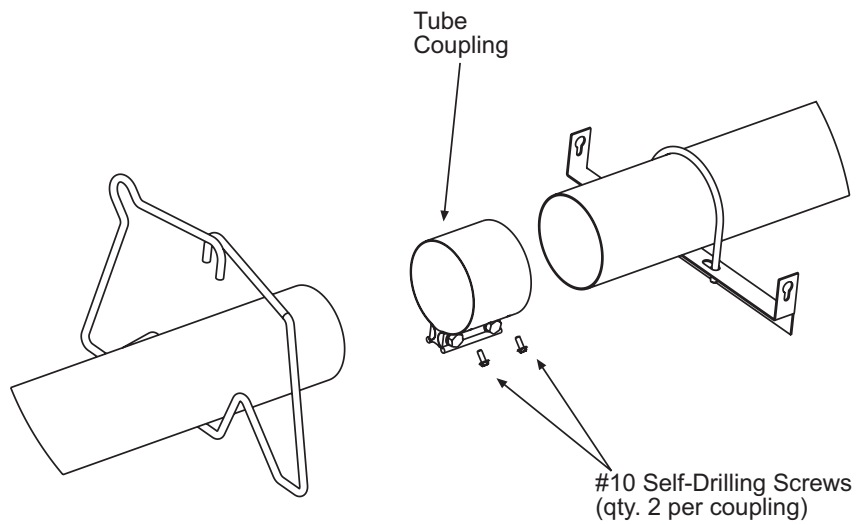

IMPORTANT: NEVER REUSE A COUPLING. Always install a new coupling only and torque as per instructions above and the diagrams above.

2. See typical assembly overview (Section 8.0) for typical complete assembly. Assemble additional extension sections as required for all systems. (See Sections 5.0, and 7.0 for typical layout details.) Note: All remaining tubes after the second section will be hot rolled steel

8.3) ADDING BODY REFLECTORS

1. Slide the reflectors on the tube support/hanger brackets and through the wire hangers.
2. The tube at the coupling joints must be covered. Slide the reflectors together and provide an overlap of two (2") inches for the first reflector overlap after the control unit. All remaining reflector overlaps will be approximately one (1") inch. This will allow for the natural expansion and contraction of the heater when in operation. **Note: The heaters can expand and contract up to 1-3/4" of an inch.**
3. Attach the reflectors as shown in Detail A using #10 x 1/2" self-drilling sheet metal screws. This is typical at each tube support/hanger bracket.

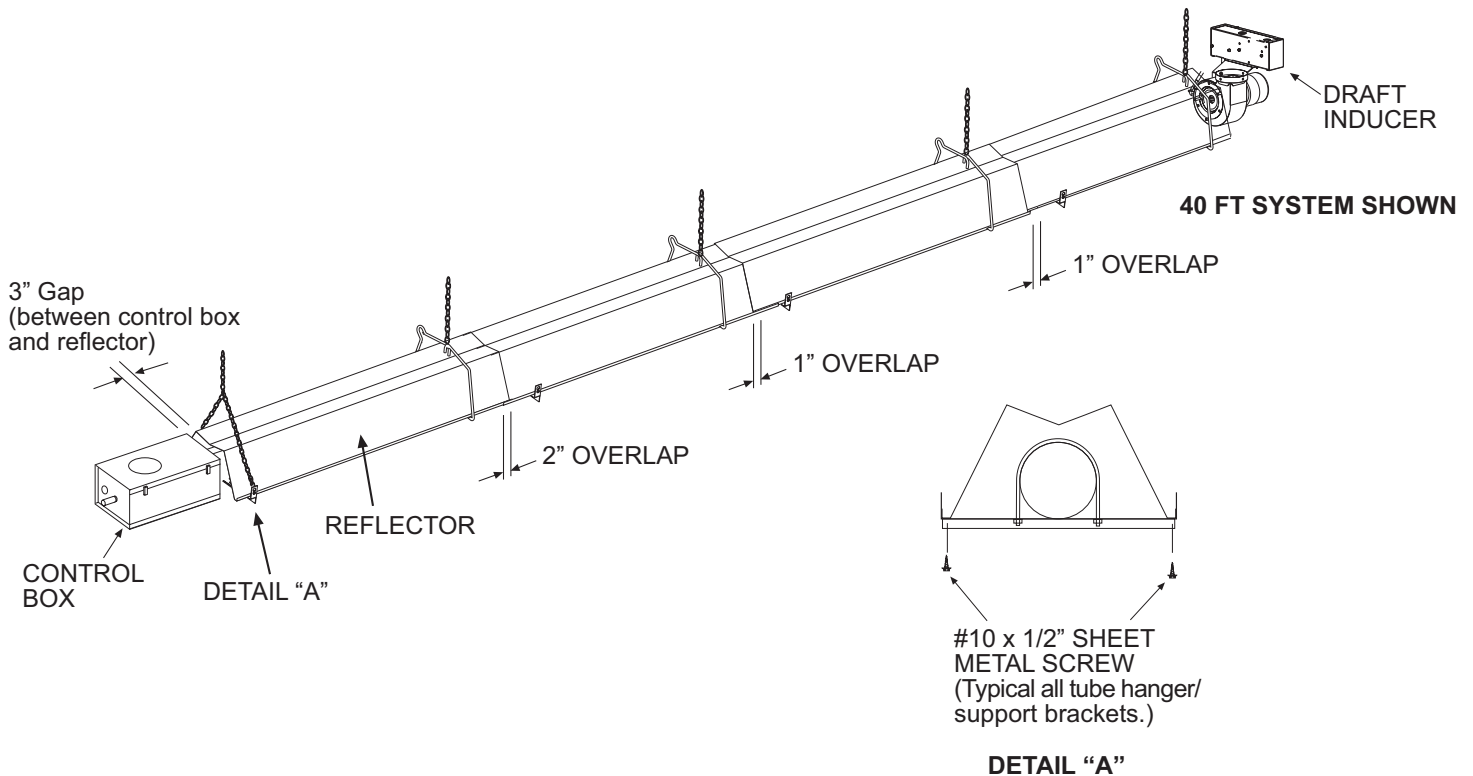

8.4) ETS/ ETU 225-250 SERIES — JOINING OF FLANGED BODY SECTIONS

The control box must be attached to a 6-hole flange on the 10 ft. Starting Body Section (this body section has a 6-hole flange at both ends of the tube). The other 6-hole flange must be connected to the 6-hole flange of the Secondary Body Section for ETS/ETU225-250 models. The 1/4-20 screws, locknuts and flange gasket required to attach these two body sections together are included in the Body Fastener Kit of the Starting Body Package. Join the two body sections together as indicated below:

1. Join the tube flanges of the body sections together with the gasket in between. Loosely attach the heater body sections together with the 1/4-20 screws and locknuts provided. **DO NOT** fully tighten the screws and locknuts yet!
2. Tighten the screws and locknuts using the sequence shown. The screws and locknuts should be tightened a little bit at a time (the same way you would secure the lug nuts to a car wheel).
3. The remaining body section joints are coupled with a compression coupling. Refer to the previous instructions for the installation of these couplings.

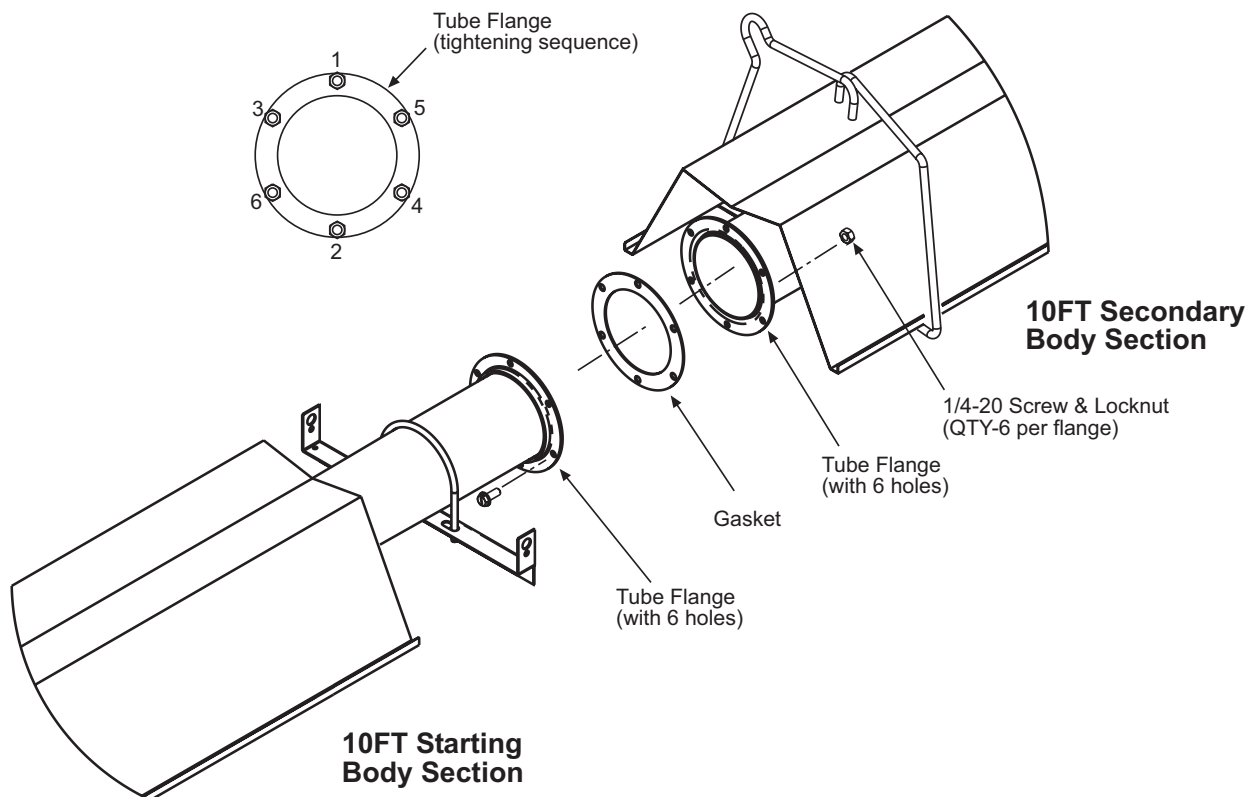

9.0) ADDING OPTIONAL 90° ELBOW (ETS ONLY)

1. The optional 90° elbow must be located a minimum of 10 ft. after the control box.
2. Hang the body sections in a 90° ("L") shaped pattern. Allow spacing for the elbow. The distance from one end of the elbow to the centerline of the opposite leg is 13" as shown.
3. Join the tube ends of the body sections and the elbow together and secure with tube couplings as described in Section 8.

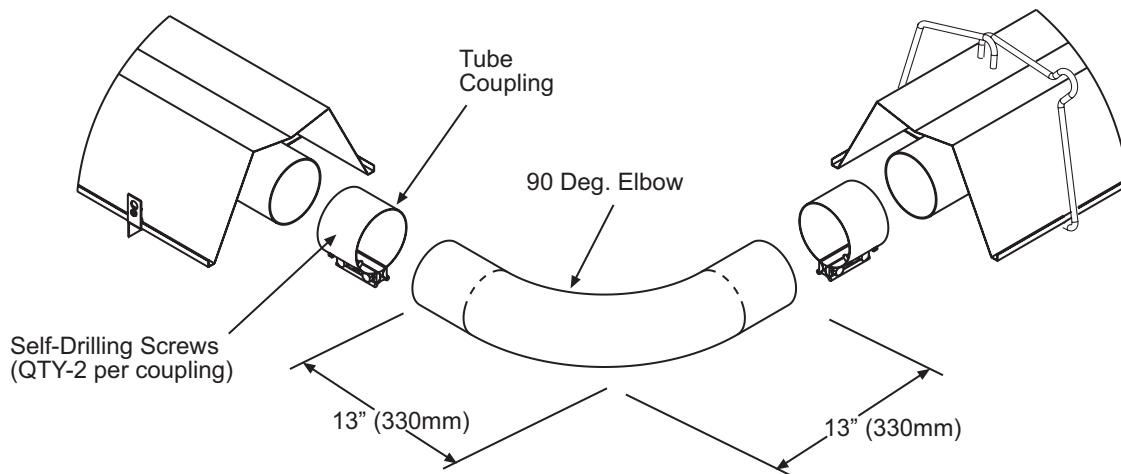

9.1) ADDING OPTIONAL CORNER REFLECTOR (ETS ONLY)

1. Place the corner reflector over the reflectors of both body sections.
2. Secure by sliding speed clips on the reflector edges. One speed clip is required for each side of reflector.
3. The corner reflector can be used only when the long axis of the heater is level and mounted in a horizontal position.

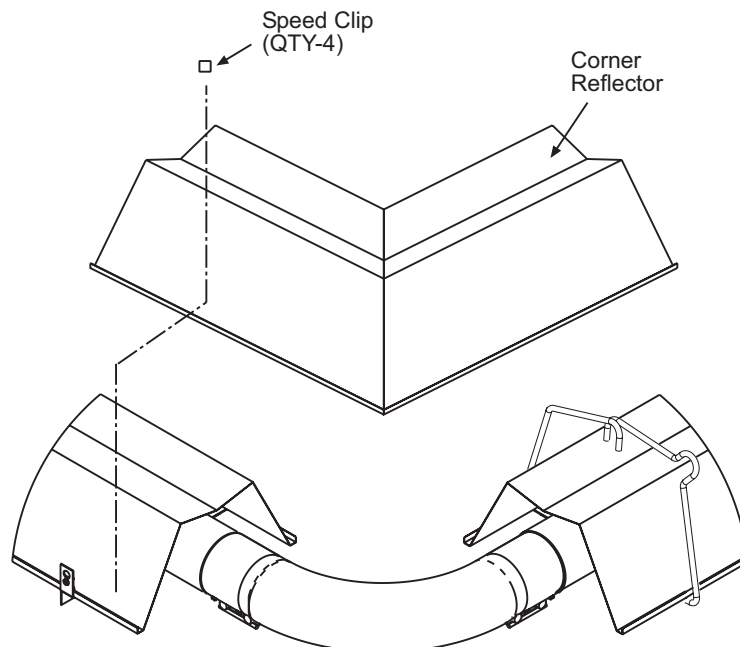

10.0) ADDING 180° U-Bend (ETU ONLY)

1. Hang body sections parallel with each other. The centerline distance from tube at each body section should be 18" as shown.
2. Join tube ends of body sections and the U-Bend together and secure with tube couplings as described in Section 8.

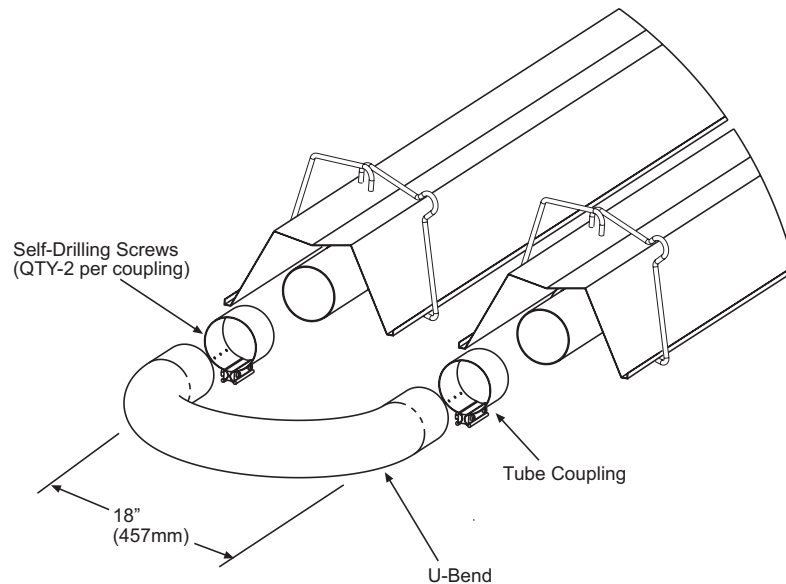

10.1) ADDING OPTIONAL U-BEND REFLECTOR (ETU ONLY)

1. Place the **U-Bend Reflector** over the reflectors of each body section with the end resting next to the tube wire hangers as shown.
2. Slide the speed clips on the reflector edges towards the end of the body section reflectors. Two speed clips are required for each side of the **U-Bend Reflector**. Make sure that the speed clips fit tightly over both the **U-Bend Reflector** and the reflector on each body section.
3. Place the **End Reflector** flush with the **U-Bend Reflector** as shown. **Note:** Clearance between end of the **U-Bend Reflector** and the **U-Bend** must be a minimum of 1". Secure by sliding speed clips onto the end reflector edges. Evenly space the speed clips on the sides (two each side) and top (three each) of the reflectors to provide a snug fit.

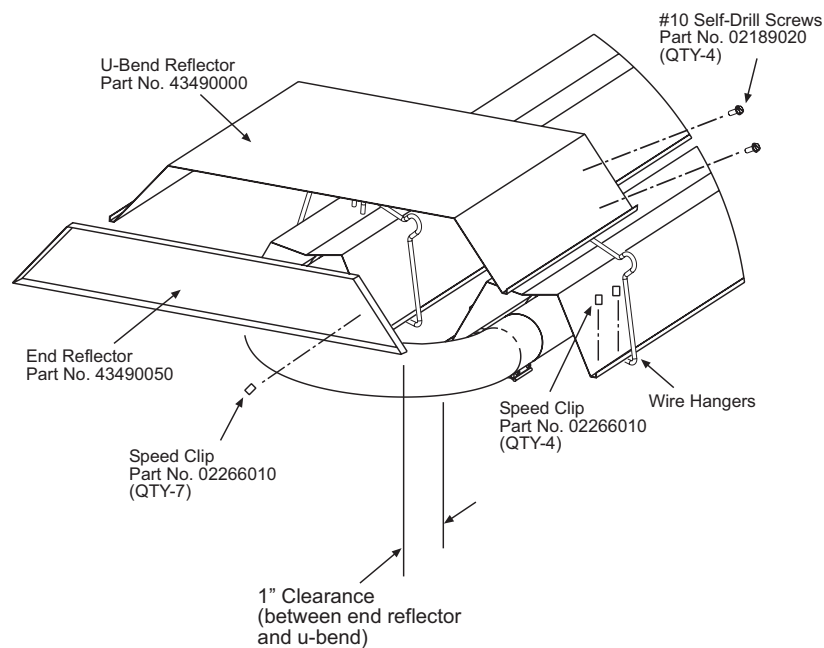

11.0) ATTACHING CONTROL BOX ASSEMBLY

1. Attach the control box and gasket to end of tube flange and secure with 1/4-20 locknuts. **NOTE: The control box must be mounted to a 10 ft. aluminized steel body section for 40-200 MBtu/hr models, or to a 10 ft. Alumi-Therm steel body section for 225-250 MBtu/hr models, regardless of configuration used. Failure to attach the control box to the flange end as indicated above will void the manufacturer's warranty.**
2. A 3/8" connector is located on the left side of the control cabinet to provide strain relief for field wiring to the draft inducer junction box and the draft inducer.)
3. Assemble the end reflector (optional on ETS, ETU series) flush with the end of the main body reflector. Secure by sliding speed clips onto the reflector edges. Evenly space the speed clips on the sides (one each side) and top (two required) of the reflectors to provide a snug fit. Leave a 3" space between the end reflector and the control box assembly.
4. The control box must be mounted with the perforated fresh air plate on top, facing the ceiling.

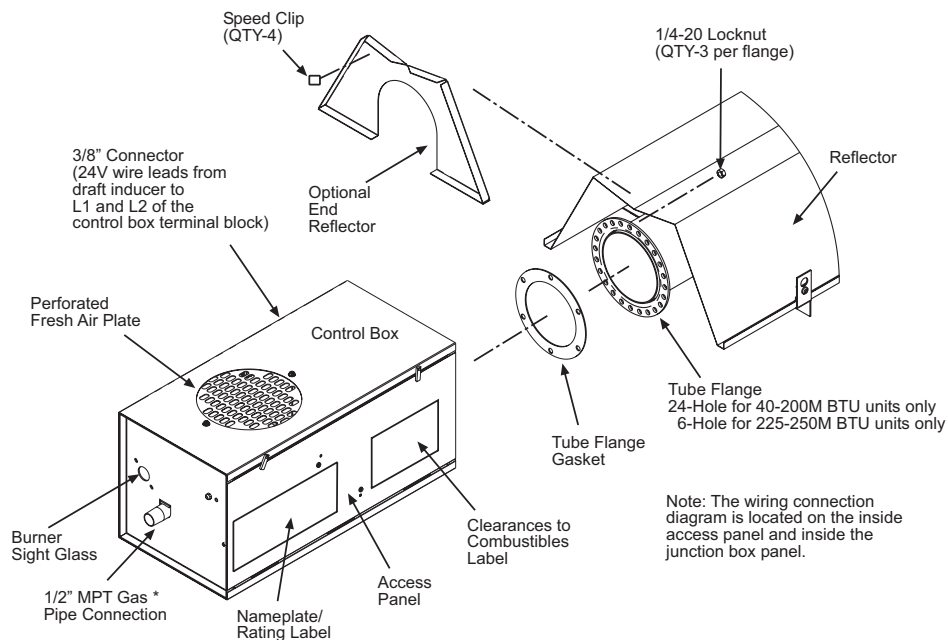

* ETS/U 200 and above require minimum 3/4" gas connector.

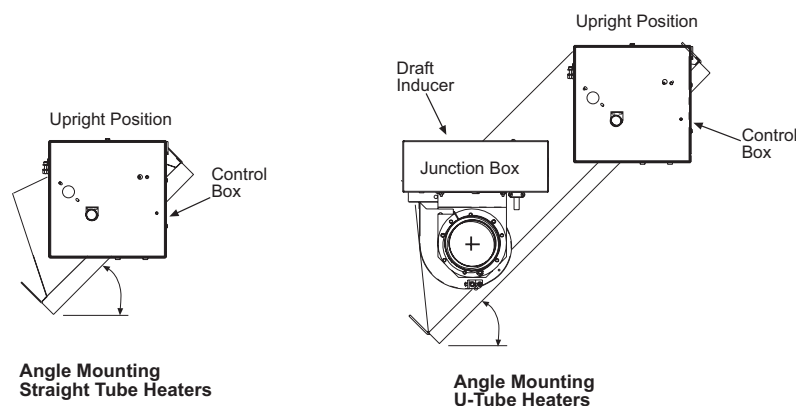

5. The heater

can be mounted **horizontally** or at an angle of up to **45 degrees** maximum from horizontal.

When angle mounting, the **control box unit must be positioned upright** as shown above. **Failure to install the control box in an upright position will void the manufacturer's warranty.** For additional instructions see Section 13 for multiple hanging and draft inducer positions.

6. **Control box** can be installed in lower side when angle mounting. Please ensure that there is adequate clearance to open the **control box** access panel for servicing the heater.

12.0) ATTACHING DRAFT INDUCER ASSEMBLY

1. Slide the draft inducer flange over the end of tube. Rotate the flange until the tightening brackets are in the upright position. Secure the flange by tightening the 1/4-20 screw located on the tightening brackets.
2. Attach the draft inducer assembly and gasket to end of the draft inducer flange and secure with 1/4-20 locknuts. A flue restrictor plate is attached to the draft inducer weld studs. Make sure this remains in place while the draft inducer is being attached to the heater body. **NOTE:** The draft inducer can be mounted in a vertical, a 45°, or a horizontal position. Refer to the diagram on Multiple Hanging and Draft Inducer Positions (Section 13.0).
3. The 3/8" connector used to hold the SJO cable will remain to provide strain relief for field wiring of the control box and the draft inducer (refer to the Electrical Connections and Connection Wiring Diagram for wiring between the control box and the draft inducer in Section 16.0).
4. If the heater is to be VENTED to the outside of the building, place the starting collar on the outlet of the draft inducer and secure with the #8-32 screws and nuts. Place the flue pipe directly onto the starting collar, secure with the #8 sheet metal screws, and terminate with an approved vent cap.
5. If the heater is for UNVENTED use, place the exhaust hood (supplied as an accessory) directly onto the outlet of the draft inducer (starting collar is not necessary for unvented use). Secure with the #8 sheet metal screws. **The exhaust hood must be mounted only in an upright position and directed toward the reflector body.**
6. Assemble the end reflector (optional on ETS, ETU series) flush with the end of the main body reflector. Secure by sliding speed clips onto the reflector edges. Evenly space the speed clips on the sides (one each side) and top (two required) of the reflectors to provide a snug fit. Leave a 3" space between the end reflector and the draft inducer assembly.

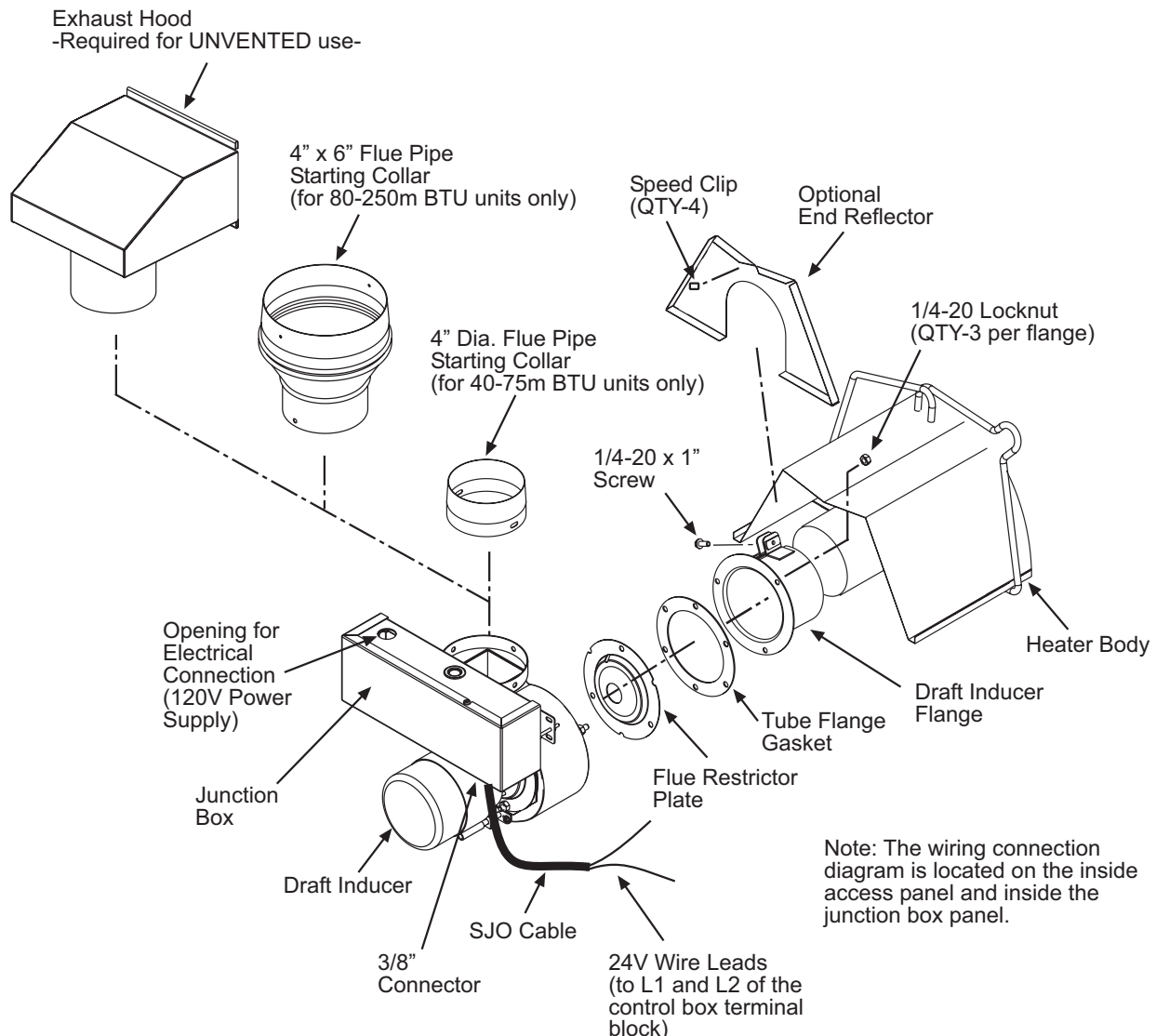

13.0) MULTIPLE HANGING & DRAFT INDUCER POSITIONS —

The heater can be mounted horizontally or at an angle of 45° maximum from horizontal. Make sure the long axis of heater is level.

Multiple draft inducer positions can also be used as shown in the diagrams. This allows for the desired configuration of flue venting. Regardless of the position chosen, the junction box must remain horizontal as shown. This may be achieved as follows:

1. Remove the three (3) 1/4-20 locknuts securing the motor and blower wheel assembly.
2. Pull the motor and blower wheel assembly with the motor plate slightly from the end of the housing studs. Use care not to damage the motor leads.
3. Rotate the junction box assembly to the upright position using the multi-hole mounting bracket.
4. Replace the motor and blower assembly. Tighten the locknuts.
5. Horizontal and 45° draft inducer positions can allow the plastic vacuum air tube to sag. The air tube should be shortened to prevent a downward sag that could allow condensation build-up in the tube.

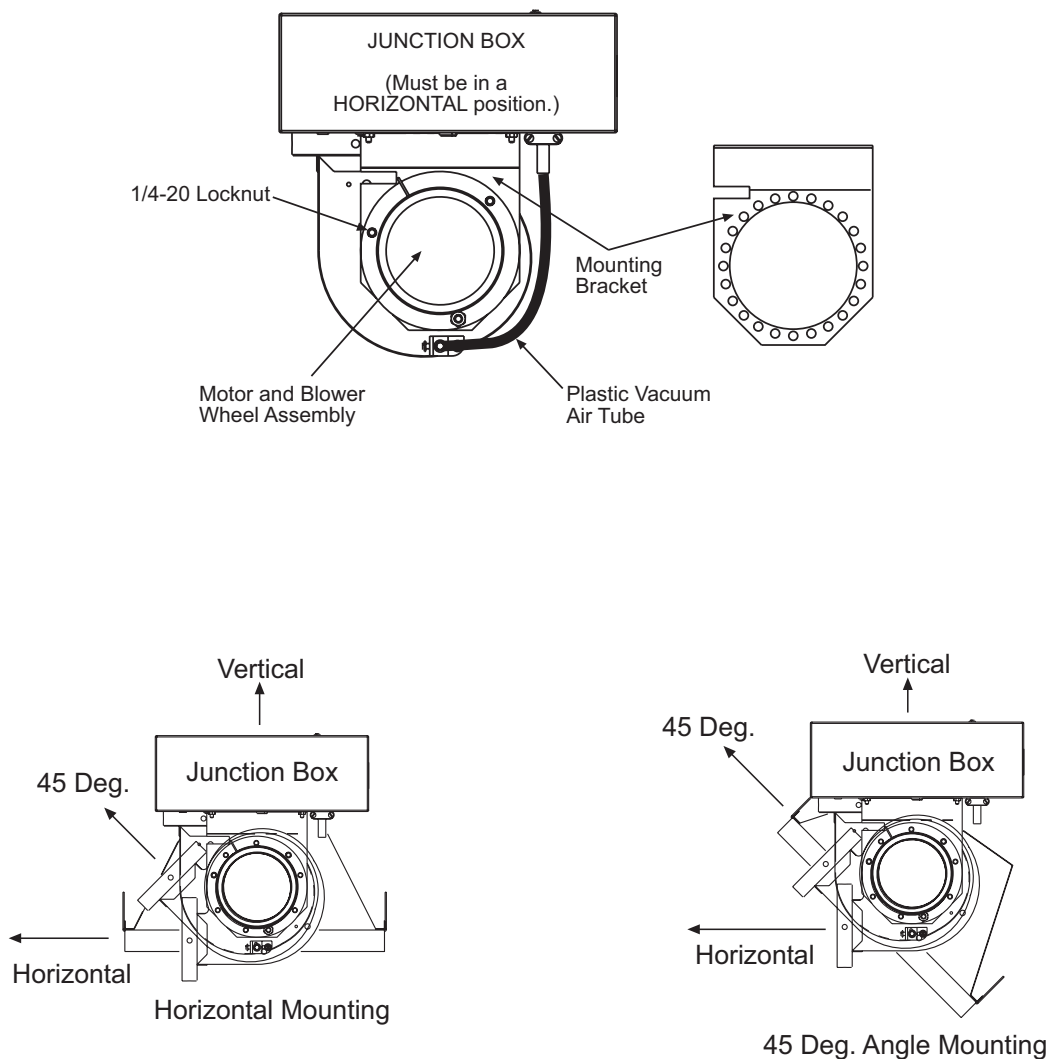

13.1) TYPICAL SUSPENSION METHODS

Various means of suspending the heater can be used. See the following drawings for typical examples.

1. Use only noncombustible materials for hangers and brackets.
2. A minimum No. 2 chain with a working load limit of 115 lbs. is required.
3. Turnbuckles can be used with chains to allow leveling of the heater. All "S" hooks and eye bolts must be manually crimped closed by the installer.
4. When using rigid means for heater suspension (rod, flat bar, etc.) provide sufficient lengths or swing joints to compensate for expansion. See Figures b and c.
5. Heaters subject to vibration must be provided with vibration isolating hangers.
6. Heaters must not be supported by gas or electric supply lines and must be suspended from a permanent structure with adequate load capacity.

Space-Ray recommends that the body sections be hung by chains with turnbuckles. This will allow slight adjustments after assembly and heater expansion/ contraction during operation.

If a "trapeze" method is used (shown below), the minimum chain length for the two connecting chains is 36". If these chains must be less than 36", then do not use the trapeze method and, instead, use individual chains on each tube support/hanger bracket.

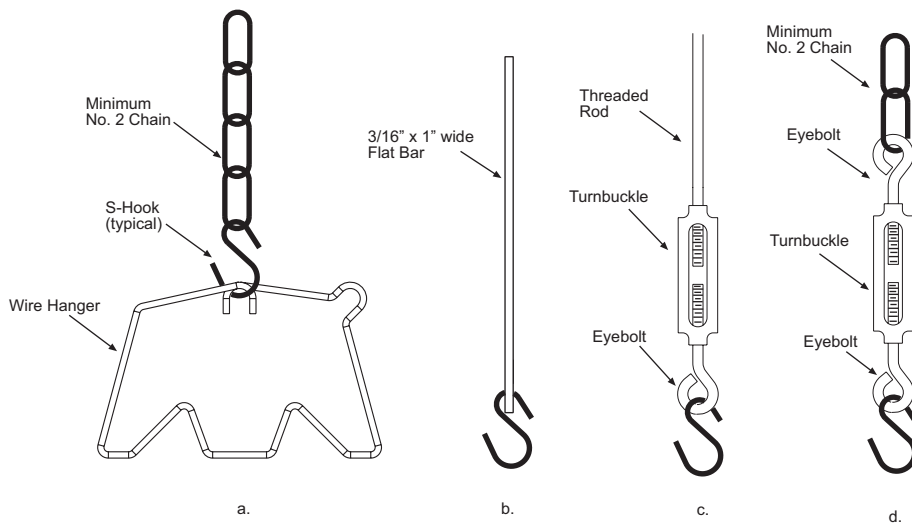

TYPICAL SUSPENSION METHODS

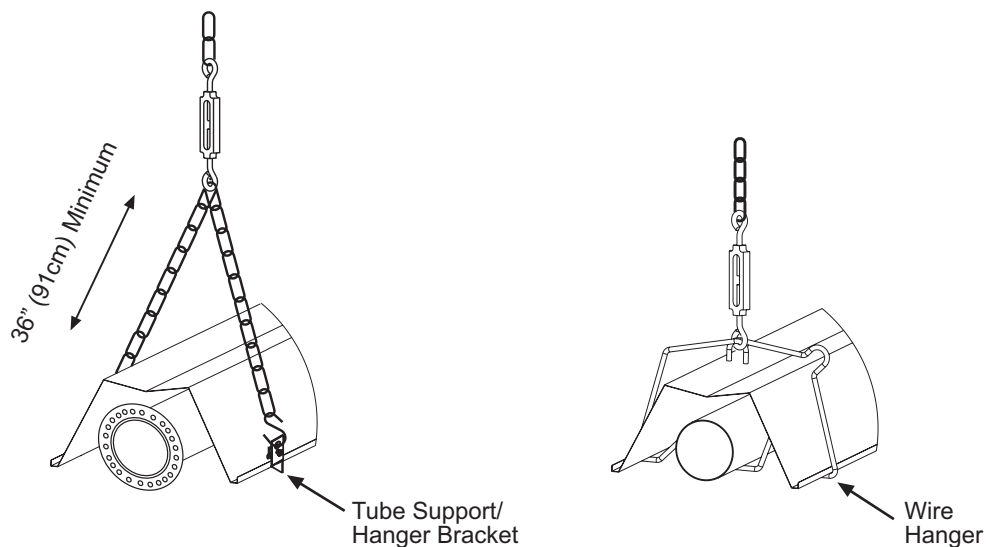

14.0) MINIMUM CLEARANCES TO COMBUSTIBLES

Minimum clearances to combustibles shall be measured from the outer surfaces as shown in the following diagram:

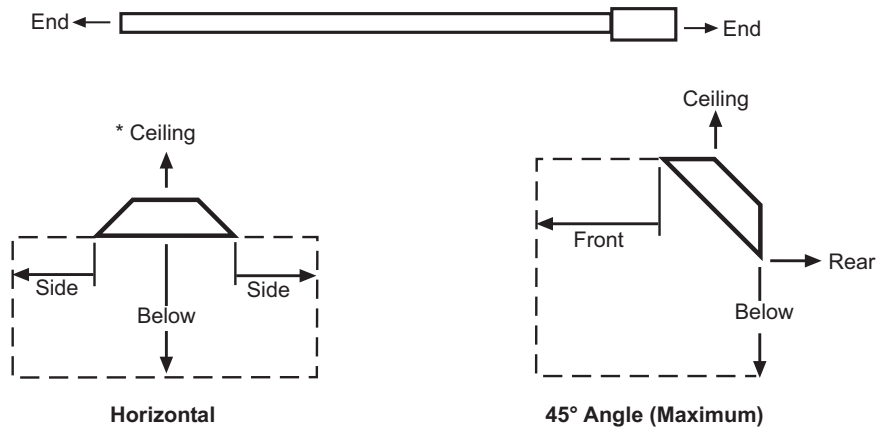

MINIMUM CLEARANCES TO COMBUSTIBLES						
Model No.	Mounted Horizontally				Angle Mounted at 45°	
	Sides	Ceiling*	Below	Ends	45° Front	45° Rear
ETS, ETU 40, 50	27"	6"	40"	30"	48"	12"
ETS, ETU 60, 75	27"	6"	60"	30"	48"	12"
ETS, ETU 80, 90	52"	6"	84"	30"	52"	12"
ETS, ETU 100	66"	6"	88"***	40"	66"	20"
ETS, ETU 110, 120, 125, 130	66"	6"	101"***	40"	66"	20"
ETS, ETU 140, 150, 160, 175	84"	6"	106"***	48"	84"	24"
ETS, ETU 180, 200, 225, 250	84"	6"	132"***	48"	84"	24"

* When used indirect vented, minimum clearance for CEILING must be: 12" for ETU, ETS 40-75 and 18" for ETU, ETS 80-250. If optional corner reflectors are not used, the clearance must be 18".

** Minimum clearance BELOW reduces to 72" once you are 20 ft. downstream from the control box.

NOTE: The clearances specified above must be maintained to combustibles and other materials that may be damaged by temperatures 90°F above ambient temperature. Clearances to combustibles are posted on the control box. In areas used for storage of combustible materials where they may be stacked below the heater, NFPA54 requires that the installer must post signs that will "specify the maximum permissible stacking height to maintain the required clearances from the heater to combustibles." Space-Ray recommends posting these signs adjacent to the heater thermostat or other suitable location that will provide enhanced visibility.

15.0) GAS CONNECTIONS AND REGULATIONS

1. Connect to the supply tank or manifold in accordance with the latest edition of National Fuel Gas Code (ANSI Z223.1), and local building codes. Authorities having jurisdiction should be consulted before the installation is made. (In Canada, refer to the latest edition of CAN Standard B.149-1 & -2, Installation Codes for Gas Burning Appliances and Equipment.)
2. All gas supply lines must be located in accordance with the required clearances to combustibles below the heater as listed on the nameplate of the heater.
3. Pipe joint compounds must be resistant to the action of liquefied petroleum gases.
4. Straight tube heaters (ETS series) can expand/contract during operation. If rigid pipe connections are planned, provisions for expansion/contraction must be provided. Where local codes do not prohibit, a CSA or U.L. approved flexible connector (minimum 5/8" I.D.) is recommended between the rigid piping and the heater. A union and an approved shut off valve should be installed before the control valve inlet. The shut off valve should be installed within 6 feet of the union.
5. This appliance is equipped with a step-opening, combination gas valve. **The maximum supply pressure to the appliance is 14" W.C. or 1/2 P.S.I.** If the line pressure is more than the maximum supply pressure, then a second stage regulator which corresponds to the supply pressure must be used.
6. If a 2nd stage regulator is used and gas seeps through it, the redundant combination gas valve is designed to lock out. Pressure build-up in the supply lines prior to the heater must be released before proper heater operation.
7. After all gas connections have been made, make sure the heater and all gas outlets are turned off before the main gas supply is turned on. Turn the gas pressure on and check for leaks. To check for leaks, apply a soap suds solution to all connections and joints or check by one of the methods listed in Appendix D of the National Fuel Gas Code. **! DO NOT USE AN OPEN FLAME OF ANY KIND TO TEST FOR LEAKS.**

TYPICAL GAS CONNECTIONS

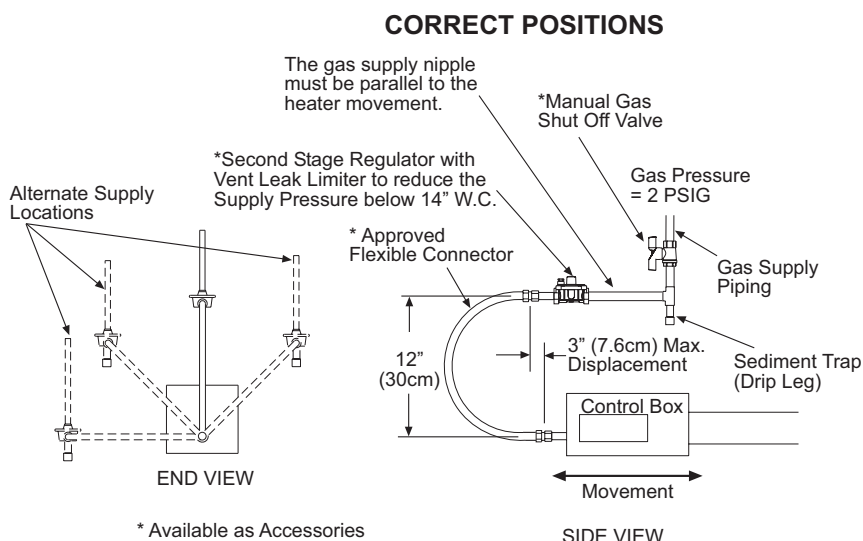

INCORRECT POSITIONS

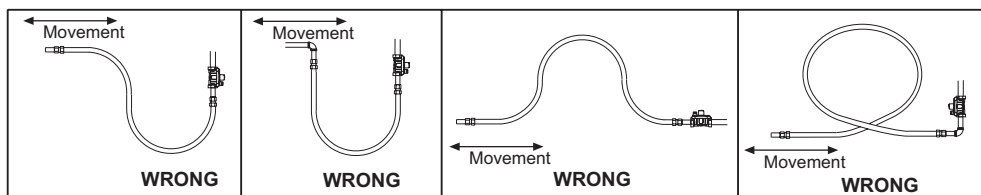

Certified connectors are recommended to be installed as shown, in one plane, and without sharp bends, kinks or twists. The gas take off from the drop line must be parallel to the burner gas inlet connection.

If the maximum supply pressure is less than 1/2 psig, a second stage regulator is not required. **NOTE: ETS, ETU 200 and above require a 3/4" flex connector.**

15.1) INSTRUCTIONS FOR PRESSURE TEST GAUGE CONNECTION

SUPPLY PRESSURE

1. The installer will provide a 1/8" N.P.T. plugged tapping, accessible for test gauge connection immediately upstream of the gas supply connection to the heater.

MANIFOLD PRESSURE

1. Turn the gas valve to the "OFF" position. Remove the 1/8" plug from the combination gas valve at the outlet pressure tap and connect a 1/8" nipple to the tapped hole. Connect the gauge to the nipple. Turn on the gas supply.
2. With the main burner operating, check the burner manifold pressure using a water manometer. Gauges that measure pressure in pounds per square inch are not accurate enough to measure or set the manifold pressure. All measurements **MUST BE** made when this heater and all other gas burning equipment that is connected to the gas supply system are operating at maximum capacity.
3. The combination gas valve is factory set and should not be adjusted. If full rate adjustment is required, remove the cover screw. Using a small screwdriver, turn the adjustment screw clockwise \curvearrowright to increase or counterclockwise \curvearrowleft to decrease the gas pressure to the burner. Replace the cover screw. **NOTE: The step opening pressure of this gas valve is not adjustable.**
4. Check the burner at step pressure, observing burner ignition and flame characteristics. The burner should ignite properly and without flashback to the orifice, and should remain lit. Cycle the burner several times. Wait 30 seconds between cycles to allow the step opening combination gas valve or servo regulator to resume the first step action. Also, observe the burner operation at full pressure. Repeat after allowing to cool. (Gas pressures are shown in the following table.)

GAS PRESSURE TABLE			
GAS TYPE	MANIFOLD PRESSURE	SUPPLY PRESSURE	
		Minimum ^W	Maximum
Natural Gas	3.5" W.C.	5" W.C.	14" W.C.
Propane Gas	10.0" W.C.	11" W.C.	14" W.C.

^W Minimum permissible gas supply pressure for purpose of input adjustment.

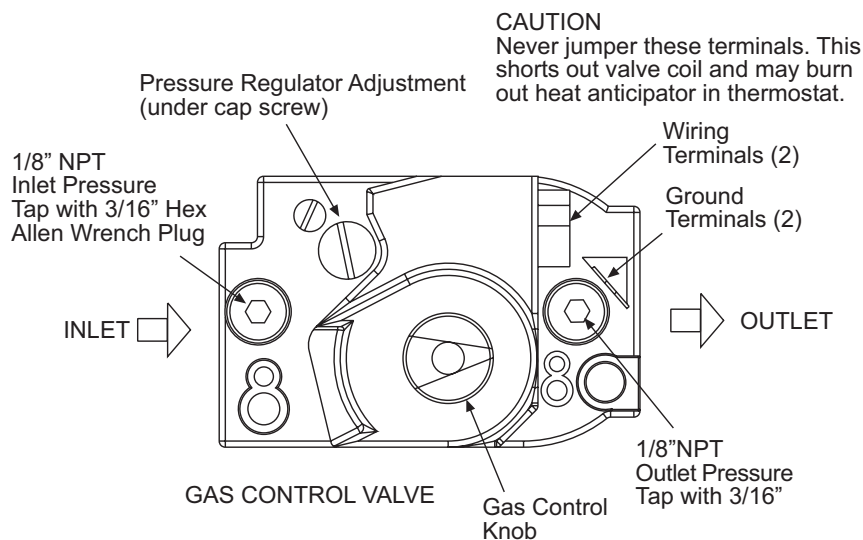

16.0) ELECTRICAL CONNECTIONS

1. All electric wiring shall conform to the latest edition of the National Electrical Code (ANSI/NFPA No. 70), or the code legally authorized in the locality where the installation is made.
2. The unit must be electrically grounded in accordance with the National Electrical Code (ANSI/NFPA No. 70-latest edition). In Canada, refer to current standard C22.1 Canadian Electrical Code Part 1.
3. The wiring providing power to the heater shall be connected to a permanently live electrical circuit, one that is not controlled by a light switch.
4. The power supply to the unit should be protected with a fused disconnect switch or circuit breaker. A service switch, as required by local codes, shall be located in the vicinity of the heater (check local codes for allowable distances) and should be identified as Heater Service Switch. All electrical wiring must be located in accordance with the required Clearances to Combustibles below the heater as listed on the nameplate on the heater.
5. When connecting the supply circuit to the heater, wiring material having a minimum size of 14 AWG and a temperature rating of at least 90°C shall be used.
6. **ETS SERIES ONLY:** The installer will provide type SJO wire cable having minimum size of 18 AWG and connect the ends to the draft inducer junction box and the control box. Secure with 3/8" connectors as previously described in the attachment of the control box and draft inducer. Connect wire leads as shown in the Connection Wiring Diagram. The SJO cable should be located and secured to protect it from mechanical damage.

CONNECTION WIRING DIAGRAM — Direct Spark Ignition — (ETS, ETU40-250 MODELS ONLY)

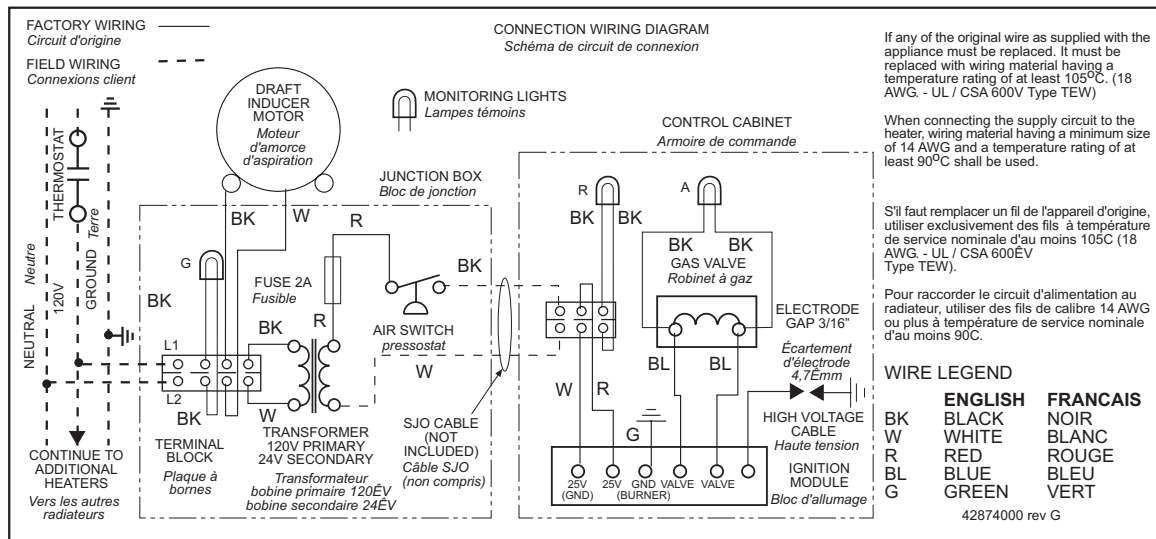

NOTES:

1. If any of the original wire as supplied with the appliance must be replaced, it must be replaced with wiring material having a temperature rating of at least 90°C. (18 Ga. CSA 600V Type TEW)
2. When connecting the supply circuit to the heater, wiring material having a minimum size of 14 AWG and a temperature rating of at least 90°C shall be used.
3. A replaceable 3-amp fuse (1-1/4" long) is fitted to the Ignition Control Module.

TYPICAL WIRING AND THERMOSTAT CONNECTIONS

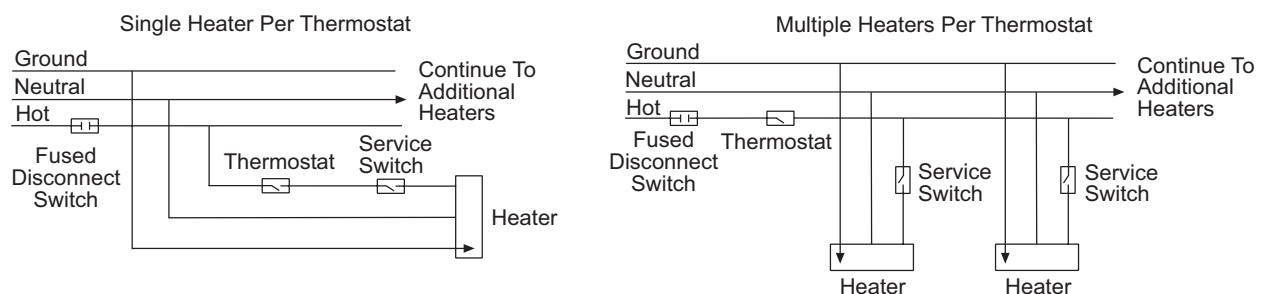

17.0) VENTING

- A. **BASIC FLUE VENTING** — Venting must comply with the latest edition of the National Fuel Gas Code (ANSI Z223.1-latest edition) or the authority having jurisdiction. Other venting references are in the equipment volume of the ASHRAE Handbook.

SINGLE HEATER VENTING (VERTICAL THROUGH THE ROOF)

1. When venting the heater to outside of building through a roof, use single-wall metal pipe. This is to be constructed of galvanized sheet metal or other approved noncombustible corrosion-resistant material as allowed by state or local codes.
2. A vent passing through a combustible roof shall extend through an approved clearance roof thimble. Double-wall, Type B vent must be used for the portion of the vent system which passes through the roof. An approved vent cap (Leslie "VersaCap"-Type B or equal) must be attached to end of the flue.
3. The maximum equivalent length of vent pipe should be carefully observed. A safety switch in the heater is designed to shut the heater off before excessive flue restriction causes bad combustion. Refer to the Vent Sizing Table at the end of this section for required vent pipe diameter.
 - Minimum Equivalent Length = 5 ft. of Pipe
 - Maximum Equivalent Length = 100 ft. of PipeUse the following correction factors to obtain the equivalent length:
 - a. Subtract 15 ft. if the run is horizontal.
 - b. Subtract 10 ft. for an approved vent cap.
 - c. Subtract 10 ft. for each elbow beyond 15 ft. from the heater.
 - d. Subtract 15 ft. for each elbow within 15 ft. of the heater.
4. Avoid locating elbows in the first 5 ft. of vent pipe whenever possible. Limit to (2) 90° elbows. When vent pipe is in a horizontal run, it must have 1/4 inch per foot rise.
5. Joints between sections of piping shall be fastened by sheet metal screws or other approved means and should be sealed to prevent leakage of flue gas into building. Aluminum or Teflon tape suitable for 550°F (3M Company tapes 433 or 363) or silicone sealant is recommended.
6. All portions of the vent pipe shall be supported to prevent from sagging.
7. When the vent pipe passes through areas where the ambient temperature is likely to induce condensation of the flue gases, the vent pipe should be insulated and a condensation drain should be provided.
8. Minimum clearance for single-wall flue pipe to combustible material shall be 6 inches. This may be reduced when the combustible material is protected as specified in the National Fuel Gas Code or the authority having jurisdiction.
9. Single-wall metal pipe shall not originate in any unoccupied attic or concealed space and shall not pass through any attic, inside wall or concealed space, or through any floor. For the installation of a single-wall metal pipe through an exterior combustible wall, refer to latest edition of the National Fuel Gas Code or the authority having jurisdiction.
10. A venting system shall terminate at least 3 ft. above any forced air inlet located within 10 ft.

SINGLE HEATER VENTING (HORIZONTAL THROUGH SIDEWALL)

When venting the heater horizontally through a combustible outside sidewall, the same requirements listed previously for venting **Vertical Through The Roof** apply *except* as follows:

1. A vent passing through a combustible wall must pass through an approved clearance thimble (Air-Jet #4VT or #6VT or Ameri-Vent #4EWT or #6EWT) or other thimbles that are listed by a nationally recognized testing agency.
2. An approved vent cap (Bredert-Type L or equal) must be attached to the end of the vent pipe.
 - Minimum Equivalent Length = 5 ft. of Pipe
 - Maximum Equivalent Length = 75 ft. of Pipe**NOTE:** To minimize problems associated with condensation in long horizontal runs, vent pipe can be insulated.
3. When venting through a sidewall, the horizontal vent pipe shall rise not less than 1/4 inch per foot from the start of the vent system to the vent terminal. All portions of the vent pipe shall be supported to prevent sagging.
4. A minimum clearance of 6 inches must be maintained between the outside wall and vent cap.
5. The horizontal venting system shall not terminate:
 - a. Less than 4 ft. (1.2m) below, 4 ft. (1.2m) horizontally from or 1 ft. (30cm) above any door, operable window or gravity air inlet into any building. The bottom of the vent terminal shall be located at least 7 ft. (2.1m) above grade or above snow accumulation level as determined by local codes.
 - b. Less than 3 ft. (0.9m) from a combustion air inlet.
 - c. Less than 3 ft. (0.9m) from any other building opening or any gas service regulator.
 - d. Directly over areas where condensate or vapor could create a nuisance or hazard or be harmful to the operation of gas utility meters, regulators, relief valves, or other equipment. Building materials should be protected from flue gases and condensate.
6. In regions of the country where prevailing winds are consistently higher than 40 mph, it may be necessary to terminate the vent system above the roof level.

MULTIPLE HEATER VENTING (CONNECTIONS INTO A COMMON VENT OR MANIFOLD)

Requirements for venting of multiple heaters are the same as described for **SINGLE HEATER VENTING** except as follows:

1. The common vent size and total vent height is normally determined by the number of heaters per common vent, length of horizontal connector runs, and connector rise. Connector lengths should be as short as possible and have a minimum 1/4" per ft. rise. Without regard to connector rise and total vent height due to many possible venting configurations, the following should be observed:
 - a. Common vent pipe & vent connector diameter should be no less than that shown in the following Vent Sizing Table.
 - b. The connector length should be no more than 75% of the vertical portion of vent above the connector.
 - c. Where possible, use a Y-connector to the common vent.
2. Material for connectors should be constructed of galvanized sheet metal or other approved noncombustible corrosion resistant material as allowed by state or local codes. All common vent pipe should be double wall, Type B vent.
3. Avoid unnecessary bends. Limit to two (2) 90° elbows.
4. The entire length of vent connector shall be readily accessible for inspection, cleaning and replacement.
5. Groups of heaters with a common vent must be controlled by a common thermostat.

▲WARNING: COMMON VENTING OF MULTIPLE HEATERS IN CONFINED SPACES IS PROHIBITED. If any heater connected to a common vent system for multiple heaters is found inoperative, the heater should be disconnected from the vent system and its entrance into the vent system capped.

B. INDIRECT VENTING (UNVENTED HEATERS) — This heater requires ventilation in the building to dilute the products of combustion and provide fresh air for efficient combustion. Where unvented heaters are used, gravity or mechanical means shall be provided to supply and exhaust at least 4 CFM per 1,000 Btu/hr input of installed heaters. Exhaust vents must be located at the highest point above and in the vicinity of the heaters, and the inlet vents must be located below the level of the heaters. An exhaust hood (Part #42924000) must be placed on the outlet collar of the draft inducer or on the existing 4" starting collar for 20-75 MBtu/hr models when used unvented and must be mounted only in an upright position and directed towards the reflector body.

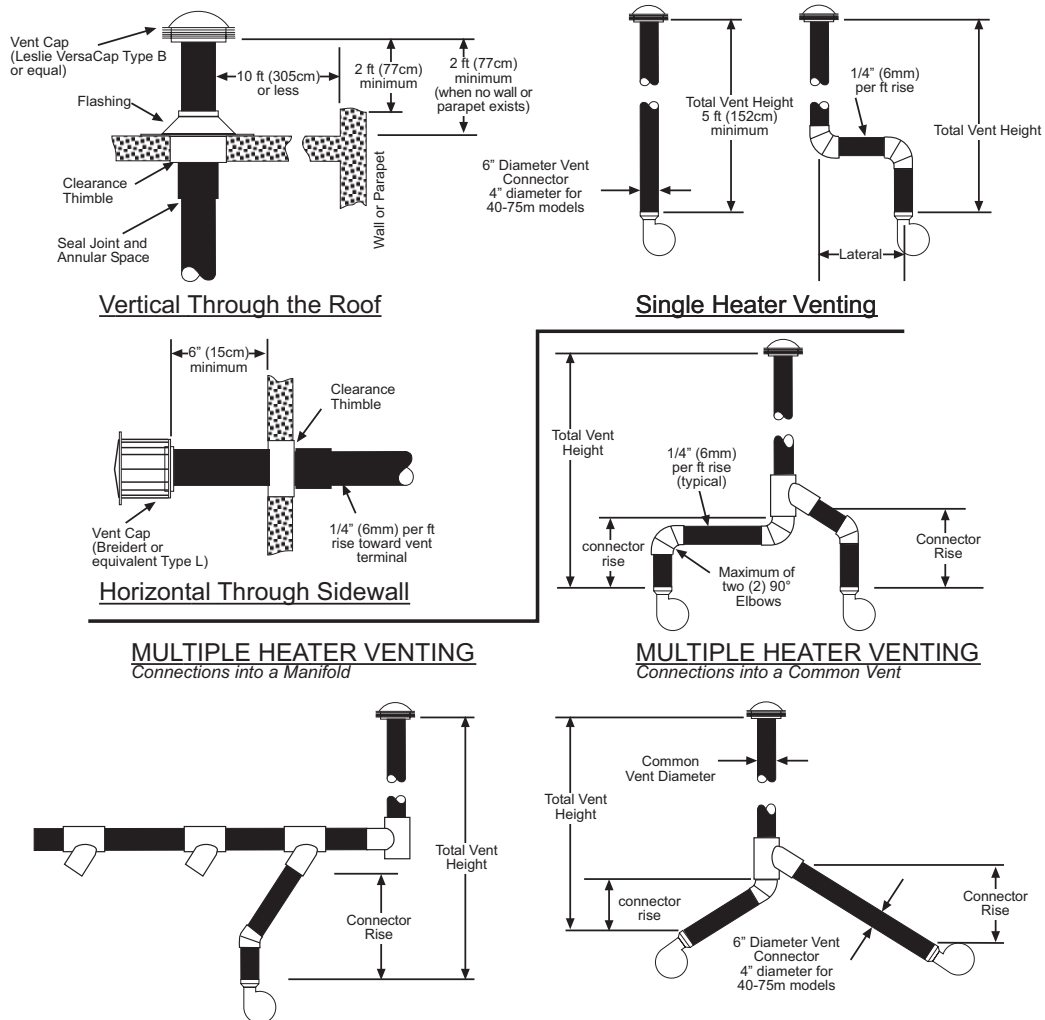

THE FOLLOWING

ILLUSTRATIONS AND TABLE OF VENT SIZES FOR COMMON VENTING OF MULTIPLE HEATERS ARE IN ACCORDANCE WITH THE NATIONAL FUEL GAS CODE ANSI Z223.1-

VENT SIZING TABLE – Multiple Heater Venting					
	Number of Heaters				
	1	2	3	4	5
ETS, ETU 40 - 50	4"	4"	5"	5"	6"
ETS, ETU 60 - 75	4"	5"	6"	6"	7"
ETS, ETU 80 - 100	6"	6"	6"	7"	8"
ETS, ETU 110 - 130	6"	6"	7"	8"	9"
ETS, ETU 140 - 175	6"	8"	8"	9"	10"
ETS, ETU 180 - 200	6"	8"	9"	10"	11"
ETS, ETU 225 - 250	6"	9"	10"	11"	12"
COMMON VENT DIAMETER (If a size is not available use the next larger size.)					

17.1) AIR FOR COMBUSTION

If indoor combustion air is to be supplied for a tightly enclosed area, one square inch of free area opening shall be provided below the heater for each 1,000 Btu/hr of heater input. Adequate clearances around the perforated fresh air plate must be maintained at all times. In larger open areas of buildings, infiltration normally is adequate to provide air for combustion.

17.2) DIRECT OUTSIDE AIR FOR COMBUSTION

Outside combustion air should be supplied directly to the heater when the building is subject to negative pressure, or when contaminants or high humidity are present in the building air. These contaminants include paints, solvents, corrosive vapors or any other foreign particles that may cause damage to the heater or result in poor combustion.

Outside combustion air can be brought directly to the heater by a 6" diameter^W duct less than 50 ft. long or equivalent. This is attached to a 6" diameter^W starting collar. The starting collar is fitted to the top of the control cabinet **after first removing and discarding the perforated cover**. An approved vent cap must be placed directly on the end of the outside combustion air inlet pipe. The combustion air inlet should be a minimum of 3 ft. (0.9m), either vertically or horizontally, from the flue vent termination. The air intake terminal must be located not less than 1 ft. (30cm) above grade. It is good installation practice to supply combustion air from the same pressure zone as the vent outlet. Avoid bringing combustion air to the heater from an attic space. There is no guarantee that adequate combustion air will be supplied.

If the heater is installed less than 2 ft. from the ceiling, a flexible transition section (e.g., flexible aluminum duct) must be provided to allow for expansion/contraction of straight tube heaters (ETS series).

In colder climates, where necessary, insulate the outside combustion air duct. Avoid locating the outside combustion air duct directly above the control box. Provide a capped cleanout T as necessary. In high humidity applications, the control box should be sealed with silicone sealer.

In multiple heater applications, the combustion air intake may be ducted individually or common ducted in the same configuration as shown for venting in Section 17. For combustion air intake duct sizing, please refer to the **Vent Sizing Table** and use the diameter indicated, based on the number of heaters per duct.

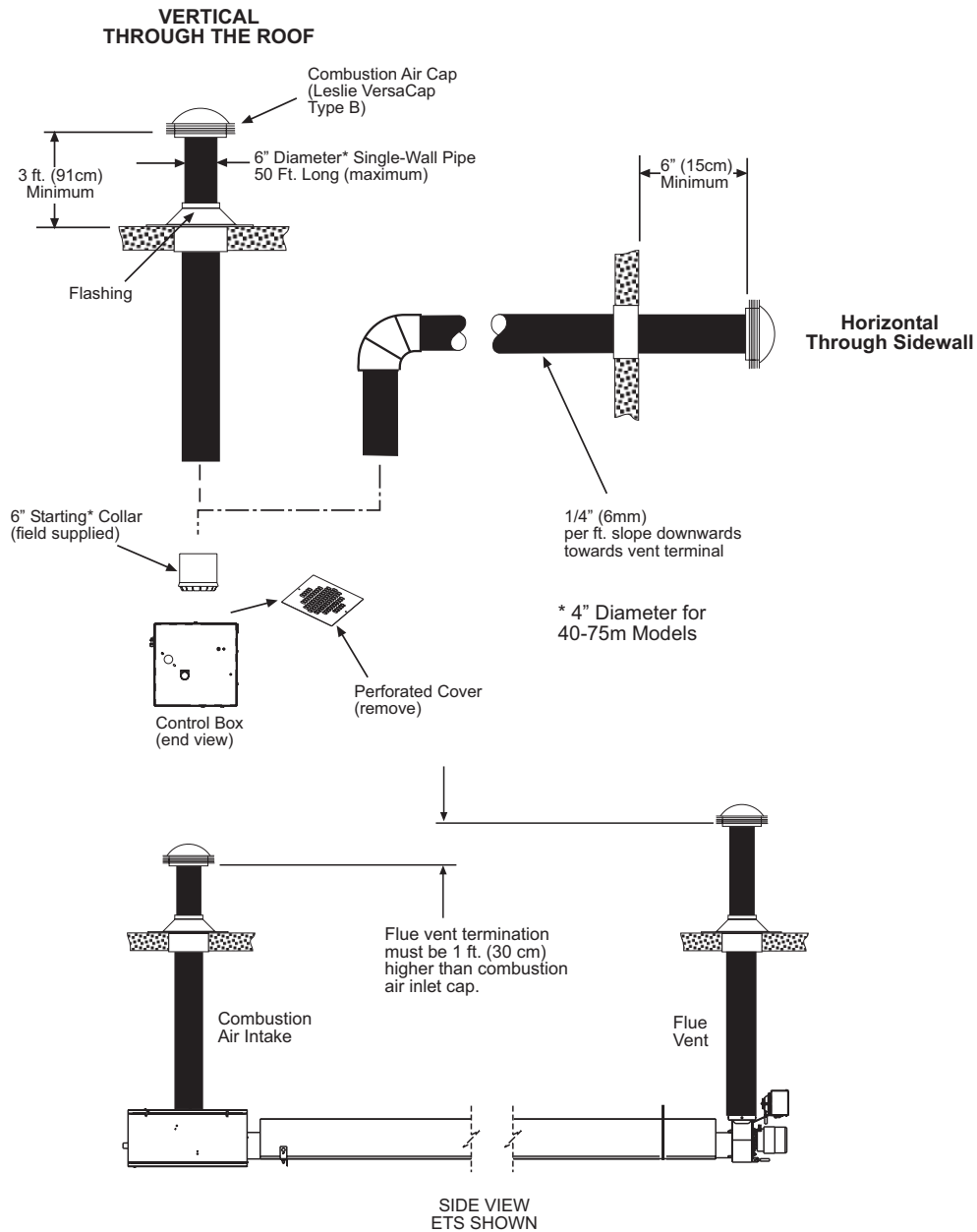

18.0) LIGHTING AND SHUTDOWN INSTRUCTIONS

- 1) Turn on the gas supply.
- 2) Set the thermostat to call for heat.
- 3) Ignition should occur after the 30-second air purge.
- 4) If ignition fails, the unit will spark for approximately 21 seconds and go into safety lockout. Turn the thermostat (power) off for 60 seconds to take the system out of lockout.
- 5) If the heater does not light, shut off gas completely for 5 minutes before attempting to relight.
- 6) **▲CAUTION:** The heater must be grounded. Poor grounding will give nuisance lockouts, particularly during momentary power interruptions.
- 7) To shut down the heater, turn off the gas and the electrical supply.

NOTE: The Lighting and Shutdown Instructions are also shown on the permanent nameplate attached to the heater control box.

19.0) IGNITION SYSTEM CHECKS

► **STEP 1: CHECK IGNITION CABLE.**

- Make sure that the ignition cable does not touch any metal surface.
- Make sure that connections to the stud terminal and the igniter/sensor are clean and tight.
- Make sure that the ignition cable provides good electrical continuity.

► **STEP 2: CHECK IGNITION SYSTEM GROUNDING.**

(Nuisance shutdowns are often caused by a poor or erratic ground.) A common ground is required for the module, igniter, flame sensor and main burner.

- Check for good metal-to-metal contact between the igniter bracket and the main burner.
- Check the ground lead from the GND (BURNER) terminal on the module to the igniter bracket. Make sure connections are clean and tight. If the wire is damaged or deteriorated, replace it.
- Replace igniter/sensor with factory replacement part if insulator is cracked.

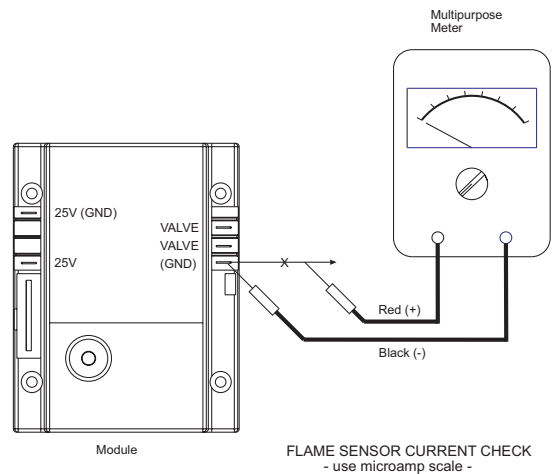

► **STEP 3: CHECK SPARK IGNITION CIRCUIT.**

ⓈWARNING: THE IGNITION CIRCUIT GENERATES A 20,000 VOLT OPEN CIRCUIT AND ELECTRICAL SHOCK CAN RESULT.

- Check ignition cable.
- Check external fuse on the module.
- Verify power (24V) at module input terminals and output terminal to gas valve.
- Replace spark module if fuse and power are OK.

► **STEP 4: CHECK FLAME SENSOR CIRCUIT.**

- Turn off heater at thermostat.
- Connect a meter (dc microammeter scale) in series with the ground lead as shown in the diagram. Use a Honeywell W136 Test Meter or equivalent. Connect the meter as follows:
 - Disconnect the ground lead at the electronic control.
 - Connect the black (negative) meter lead to the electronic control GND terminal.
 - Connect the red (positive) meter lead to the free end of the ground lead.
- Restart the system and read the meter. The flame sensor current must be steady and measure at least 1.5 micro amps.
- If the meter reads less than the minimum or if reading is unsteady:
 - Make sure burner flame is capable of providing a good rectification signal.
 - Make sure fasteners securing igniter/sensor are tightened to assure correct positions. **DO NOT** relocate igniter/sensor.
 - Check for excessive (over 1000°F) temperature at ceramic insulator on flame sensor. Excessive temperature can cause short to ground. **DO NOT** relocate igniter/sensor.
 - Check for cracked ceramic insulator, which can cause short to ground, and replace sensor if necessary.
 - Make sure that electrical connections are clean and tight. Replace damaged wire
- Remove microammeter and reconnect ground wire. Return system to normal operation.

20.0) SEQUENCE OF OPERATION

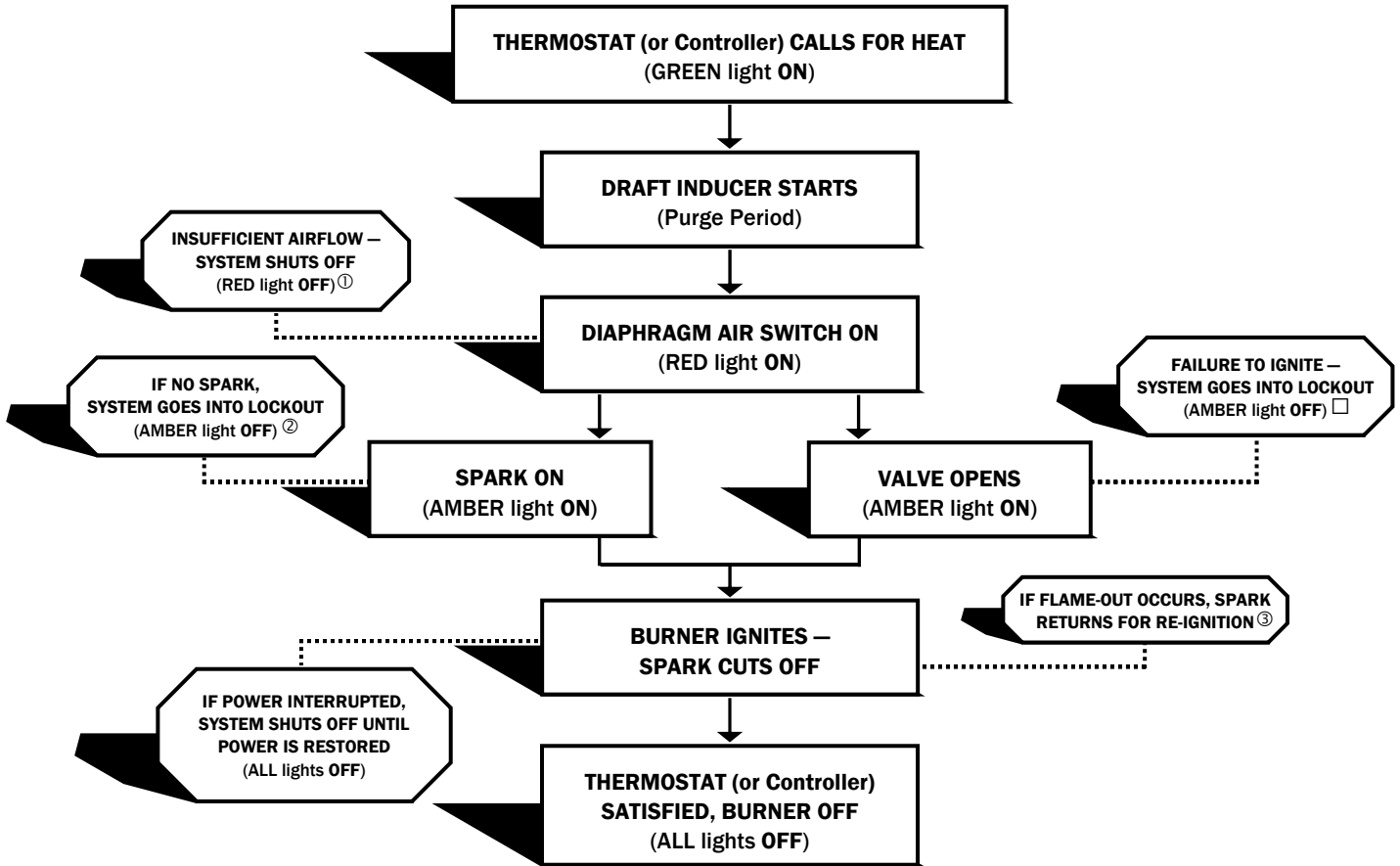

NOTES:

- ① – Insufficient airflow indicates defective draft inducer or restricted flue.
- ② – Corrective action and system reset are necessary.
- ③ – If burner does not re-ignite, system goes into lockout. Corrective action and system reset are necessary.



-- Octagons represent actions resulting from possible malfunction.

21.0) TROUBLESHOOTING

GUIDE OF DIRECT SPARK IGNITION SYSTEM

-START-

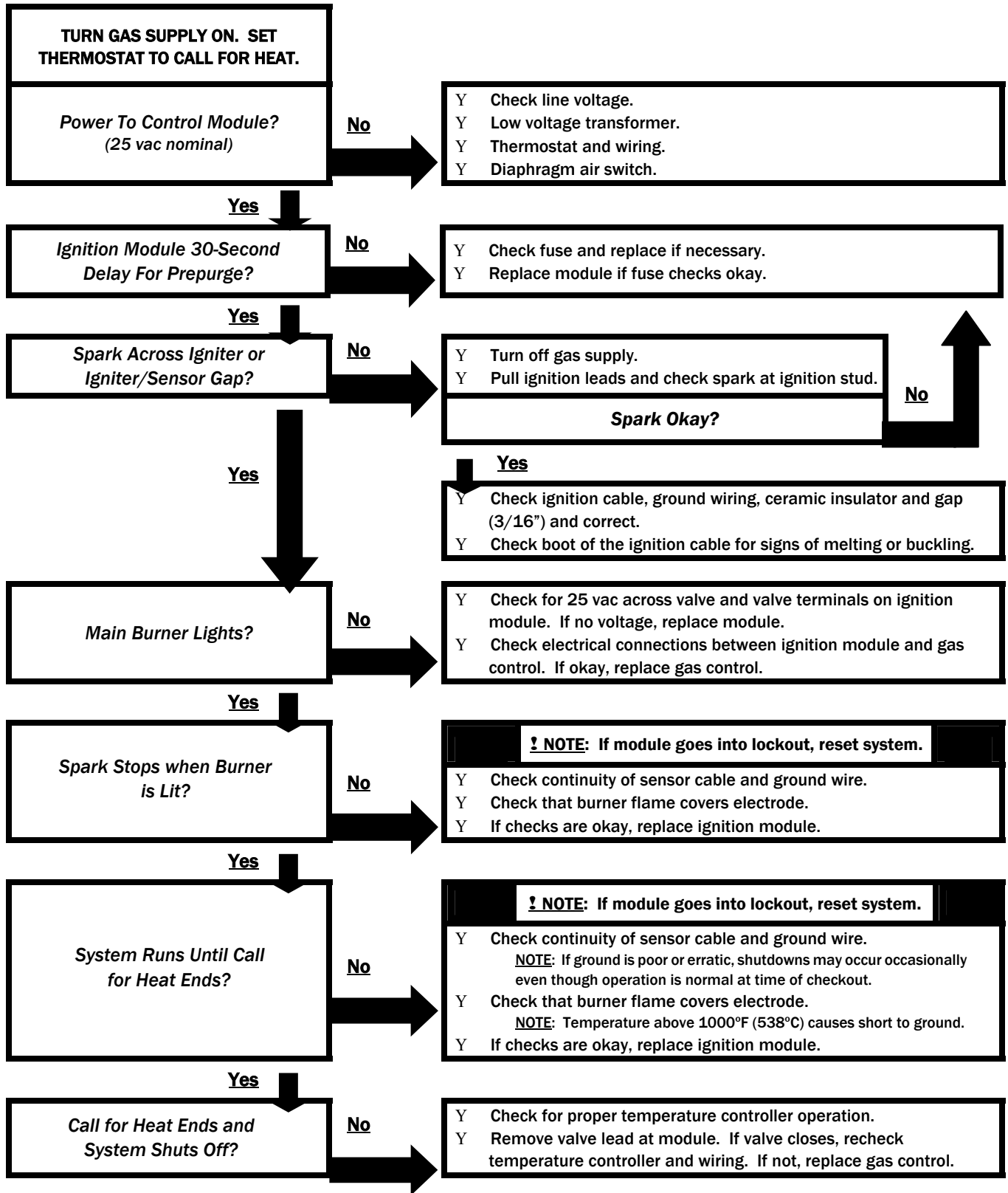

-END TROUBLESHOOTING-

REPEAT PROCEDURE UNTIL TROUBLE-FREE OPERATION IS OBTAINED.

22.0) MOTOR AND BLOWER WHEEL CHECK

If draft inducer motor fails to run: A) Check power supply to junction box. B) Check for loose or broken motor lead wire. C) Check to see that blower wheel turns freely and is not rubbing housing. Blower wheel may have worked loose from shaft and jammed against housing. D) Check for blower wheel damage; replace if necessary. If no damage, readjust blower wheel on shaft & retighten set screw. E) If all above does not correct, replace motor.

23.0) CLEANING AND ANNUAL MAINTENANCE

This heater must be cleaned and serviced annually before the start of each heating season and at any time excessive accumulation of dust and dirt is observed. Maximum heating efficiency and clean combustion will be maintained by keeping the heater clean. To clean the heater, follow these instructions: 1) Turn off all electrical and gas supply to the heater. 2) Open the control box access panel. 3) Clean the access panel, the inside of the control box, the emitter tube and the reflector panels. (Dirty reflectors will reduce output.) 4) Visually inspect the spark electrode. Remove any foreign objects from electrode tip. Set the spark gap to the proper value of 3/16". **!CAUTION: The ceramic portion of the electrode is very fragile so any cleaning or adjustments must be done with care.** 5) Disconnect the vent stack and remove any foreign material that may have collected on the blower wheel. Make sure the blower wheel is clean. A dirty wheel can reduce the volume of air pulled and can result in premature tube failure.

24.0) REPLACING PARTS

Ensure that at all times when parts are being replaced, both gas and electrical supplies are disconnected. Various parts are available from the factory for replacement by a licensed person. Refer to the Replacement Parts Guide in Section 26 for all replacement parts.

25.0) INSTALLATION DATA

Date of Installation: _____ # of Heaters in System: _____

Serial No. _____

Model: ETS or ETU _____

N = Natural Gas
L = Propane Gas

26.0) REPLACEMENT PARTS GUIDE

MODELS: ETS / ETU 40-250

DRAFT INDUCER COMPONENTS

ITEM NO.	PART NO.	DESCRIPTION
1	42917010	Draft Inducer Assembly, 180M-250M Btu/hr models
2	42917000	Draft Inducer Assembly, 40M-175M Btu/hr models
3	03723020	Blower Wheel, Beckett
3a	03723000	Blower Wheel, Revcor
4	03988120	Plastic Vacuum Air Tube, 12" long
5	42739010	Blower Housing Sub-Assembly
6	42740000	Motor Plate
7	42742000	Sensing Tube Bracket
8	42744000	Sensing Tube, Draft Inducer
9	30347000	Motor Spacer (4 per motor)
10	03868010	3/8" Connector
11	30186200	Air Switch, set @0.37" W.C., #RSS495306 (40m-175m/BTU models)
11a	30186202	Air Switch, set @0.60" W.C., #RSS495308 (180m-250m/BTU models)
13	30267000	1/2" Knockout Plug
14	30279000	Transformer, AT120B1051
15	30281000	Terminal Block, EK-204
16	30330000	Terminal Block, TFB-323
17	42709000	Terminal Block Shield
18	30220010	Monitoring Light, Green
19	02175040	Strain Relief
21	42909000	Junction Box
22	42910000	Junction Box Cover
23	42911000	Junction Box Support Bracket
24	42923000	SJO Cable Assembly
25	03721000	Motor, JB1R061N
26	03979000	Braided Fiber Glass Sleeveing, 4" Lg
27	43221000	Draft Inducer Gasket
28	42874000	Connection Wire Diagram (<i>not shown</i>)
29-38	Restrictor Plates, see <i>list below</i>	
29	42741040	Restrictor Plate, 1" I.D. (40M Btu/hr)
30	42741030	Restrictor Plate, 1-1/8" I.D. (50M Btu/hr)
31	42741020	Restrictor Plate, 1-7/32" I.D. (60M Btu/hr)
32	42741010	Restrictor Plate, 1-7/16" I.D. (75M Btu/hr)
33	42741050	Restrictor Plate, 1-1/2" I.D. (80M & 90M Btu/hr)
34	42741060	Restrictor Plate, 1-5/8" I.D. (100M Btu/hr)
35	42741070	Restrictor Plate, 1-3/4" I.D. (110M & 120M Btu/hr)
36	42741080	Restrictor Plate, 1-7/8" I.D. (125M & 130M Btu/hr)
37	42741090	Restrictor Plate, 2-1/32" I.D. (140M & 150M Btu/hr)
38	42741100	Restrictor Plate, 2-1/4" I.D. (160M, 175M, 180M Btu/hr)
38a	42741130	Restrictor Plate, 2-3/8" I.D. (200M Btu/hr)
38b	42741140	Restrictor Plate, 2-1/2" I.D. (225M Btu/hr)
38c	42741150	Restrictor Plate, 2-3/4" I.D. (250M Btu/hr)
39	42892000	Starting Collar, 4" x 6" (80M-250M Btu/hr)
40	40504020	Starting Collar, 4" (40M-75M Btu/hr)

NOTES:

- 1) Screws, Nuts and Washers are standard hardware items and can be purchased at any local hardware store.
- 2) Please order by **PART NUMBER** - not by *Item Number*.
- 3) Replacement Part Prices are available when ordering.
- 4) Please refer to complete Model Number when ordering.

Model Number Suffixes

N = Natural Gas
L = Propane Gas

DRAFT INDUCER COMPONENTS

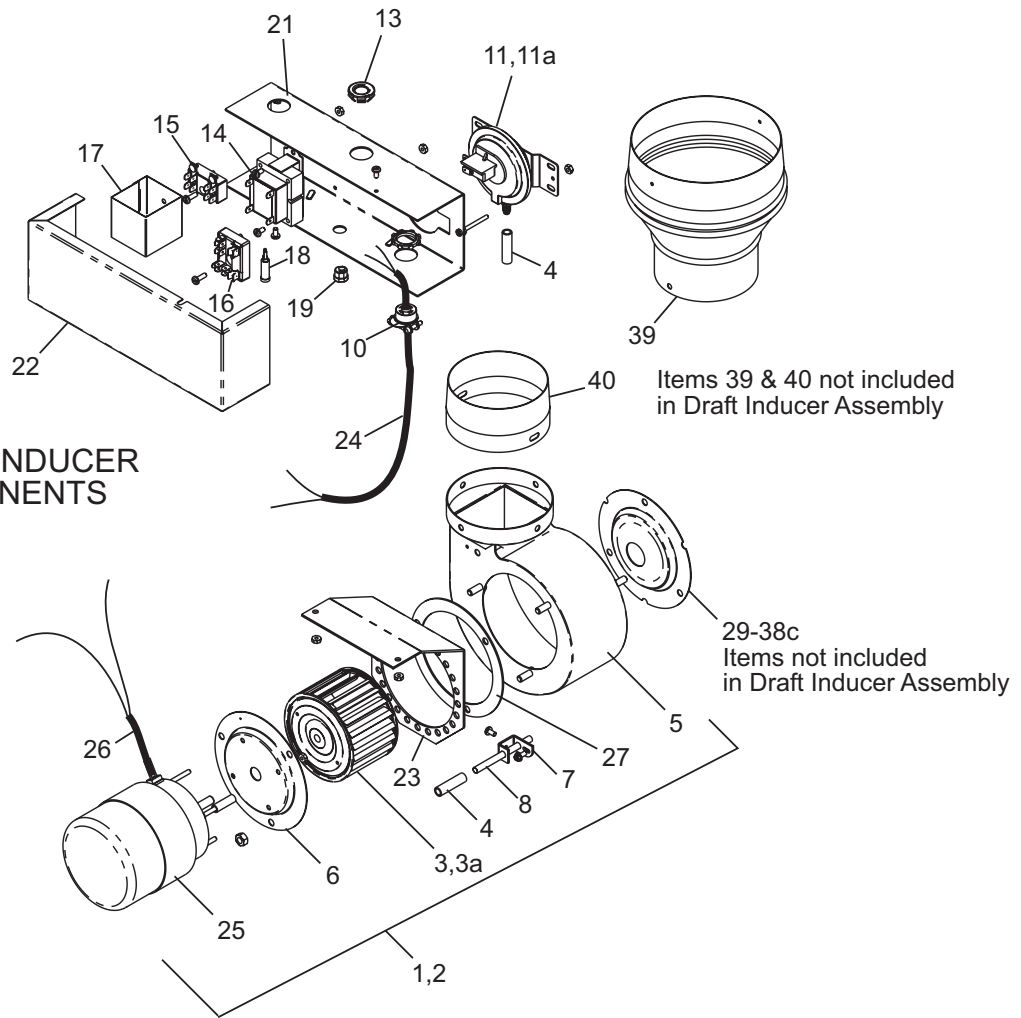

MODELS: ETS/ ETU 40-250**CONTROLBOX COMPONENTS**

ITEM NO.	PART NO.	DESCRIPTION
10	03868010	3/8" Connector
28	42874000	Connection Wire Diagram (not shown)
41	30295000	Electrode PSE-GF1 (Igniter/Sensor)
42	30314120	Ignition Cable, 14" long
43	30324000	Terminal Block, EK-104
44	30331040	Spark Module, S87J-1034
45	30220020	Monitoring Light, Red
46	30220030	Monitoring Light, Amber
47	42447000	Sight Glass
48	03339020	1/8" Plug
51	30333070	Valve, VR8205P-2408 @3½" W.C. (Natural Gas) -for 40M-200M Btu/hr Models
52	30333080	Valve, VR8205P-2416 @10" W.C. (Propane Gas) -for 40M-200M Btu/hr Models
51a	30475050	Valve, VR8305P-2208 @3½" W.C. (Natural Gas) -for 225M-250M Btu/hr Models
52a	30475010	Valve, VR8305P-2224 @10" W.C. (Propane Gas) -for 225M-250M Btu/hr Models
53	42757010	Restrainer Nipple, 4" long
54	42885000	Spark Module Shield
55	42887100	Burner Clamp
56	42890010	Burner Assembly
57	42899100	Burner Bracket Sub-Assembly
58	42888000	Electrode Bracket
59	42893000	Air Inlet Plate (Perforated)
60	42905000	Access Panel
61	42906100	Cabinet Assembly (for offset burner)
62	42889000	Orifice Fitting & Test Gauge Connection
63	03258xxx	Orifice for 80M-250M Btu/hr (State Model & Gas Type for Size)
64	43343300	Installation and Operation Instructions
67	03540090	Coupling, ½"
68	42701000	Orifice Fitting & Test Gauge Connection
69	03259xxx	Orifice for 40M-75M Btu/hr (State Model & Gas Type for Size)
70	42700000	Burner
71	43169000	Burner Clamp
72	43172100	Burner Bracket Sub-assembly
73	43170000	Electrode Bracket
74	03333120	Nipple, ½"x3½" long

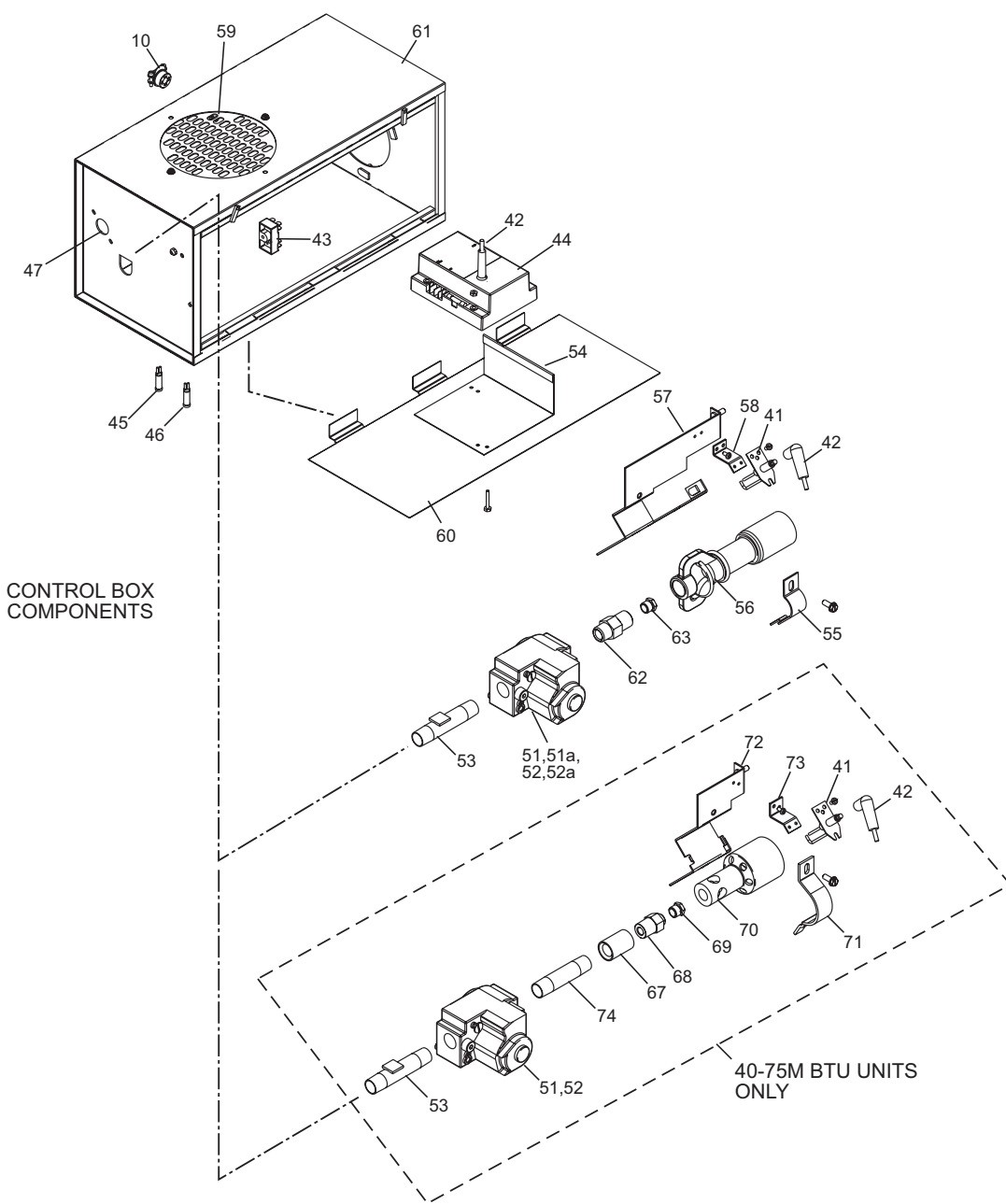

ETS/ETU BODY COMPONENTS

MODELS: ETS/ETU 40-175

ITEM NO.	PART NO.	DESCRIPTION
1	02266010	Reflector Speed Clip
2	43980010	Wire Hanger
3	42873000	"U" Bolt Clamp, 4" OD Tube
3a	02127110	5/16-18 Hex Nut (2 per "U" Bolt)
4	43318000	Tube Support/Hanger Bracket, 13"
5	43319050	Reflector, 4'-11½" long (5' section only; 1 per 5 ft. body section)
6	43319100	Reflector, 9'-11½" long (10' section only; 1 per 10 ft. body section)
7	43320000	End Reflector
8	43342000	Corner Reflector Package
9	42921000	Tube Flange Gasket
10 ^W	44028030	10' Tube Assembly Kit, 4" OD, ALC steel with one 24-hole flange (start tube)
11	44028100	10' Tube Assembly Kit, 4" OD, HR steel without flanges (extension tube & exhaust tube)
12	44028120	5' Tube Assembly Kit, 4" OD, HR steel without flanges (extension tube & exhaust tube)
13	43208010	4" O.D. Elbow Package
14	02189020	#10 x ½" Self-Drilling Screw (2 per coupling)
15	30462980	4" OD Tube Compression Coupling w/bolts
16	43208020	4" OD U-Bend (Required for ETU Only)
17	43488000	U-Bend Reflector (ETU Option)
18	44015251	Draft Inducer Flange (with 1/4-20 x 1" screw)

ALC = Calorized, Aluminized Steel
HR = Hot Rolled Steel

W Required on all models for mounting of control box.

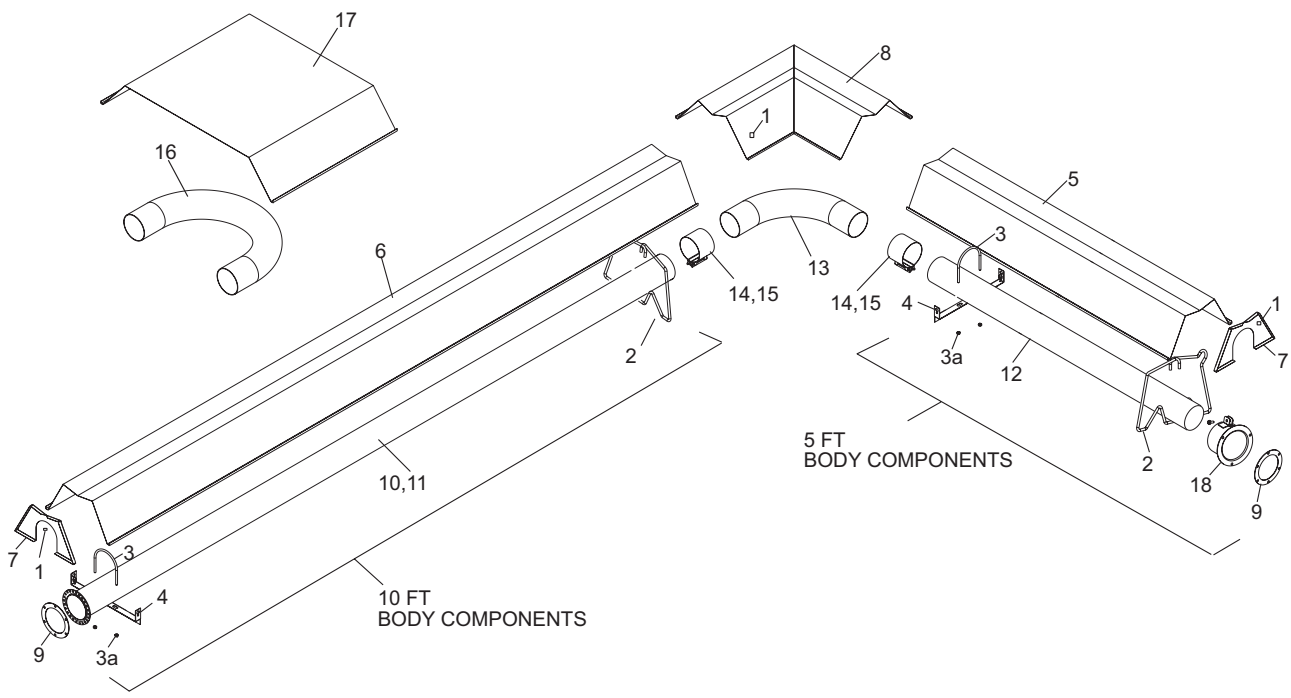

ETS/ETU40-175
 BODY COMPONENTS

ETS/ETU BODY COMPONENTS

MODELS: ETS/ETU 180-250

ITEM NO.	PART NO.	DESCRIPTION
1	02266010	Reflector Speed Clip
2	43980010	Wire Hanger
3	42873000	"U" Bolt Clamp, 4" OD Tube
3a	02127110	5/16-18 Hex Nut (2 per "U" Bolt)
4	43318000	Tube Support/Hanger Bracket, 13"
5	43319050	Reflector, 4'-11½" long (5' section only; 1 per 5 ft. body section)
6	43319100	Reflector, 9'-11½" long (10' section only; 1 per 10 ft. body section)
7	43320000	End Reflector
8	43342000	Corner Reflector Package
9	42921000	Tube Flange Gasket
10W	44028030	10' Tube Assembly Kit, 4" OD, ALC steel with one 24-hole flange ↳ for 180M-200M Btu/hr models, firing tube
11	44028050	10' Tube Assembly Kit, 4" OD, ATC steel with one 6-hole flange ↳ for 225M-250M Btu/hr models, second firing tube
12	44028060	10' Tube Assembly Kit, 4" OD, ALC steel without flanges ↳ for 180M-200M Btu/hr models, second firing tube
13	44028100	10' Tube Assembly Kit, 4" OD, HR steel without flanges ↳ for 225M-250M Btu/hr models, extension tube & exhaust tube
14W W	44028040	10' Tube Assembly Kit, 4" OD, ATC steel with two 6-hole flanges ↳ for 225M-250M Btu/hr models, firing tube
15	44028120	5' Tube Assembly Kit, 4" OD, HR steel without flanges ↳ for 180M-250M Btu/hr models, extension tube & exhaust tube
16	43208010	4" O.D. Elbow Package
17	02189020	#10 x ½" Self-Drilling Screw (2 per coupling)
18	30462980	4" OD Tube Compression Coupling w/bolts
19	43208020	4" OD U-Bend (Required for ETU Only)
20	43488000	U-Bend Reflector (ETU Option)
21	44015251	Draft Inducer Flange (with 1/4-20 x 1" screw)

W Required on 180M-200M Btu/hr models for mounting of control box.
W W Required on 225M-250M Btu/hr models for mounting of control box.

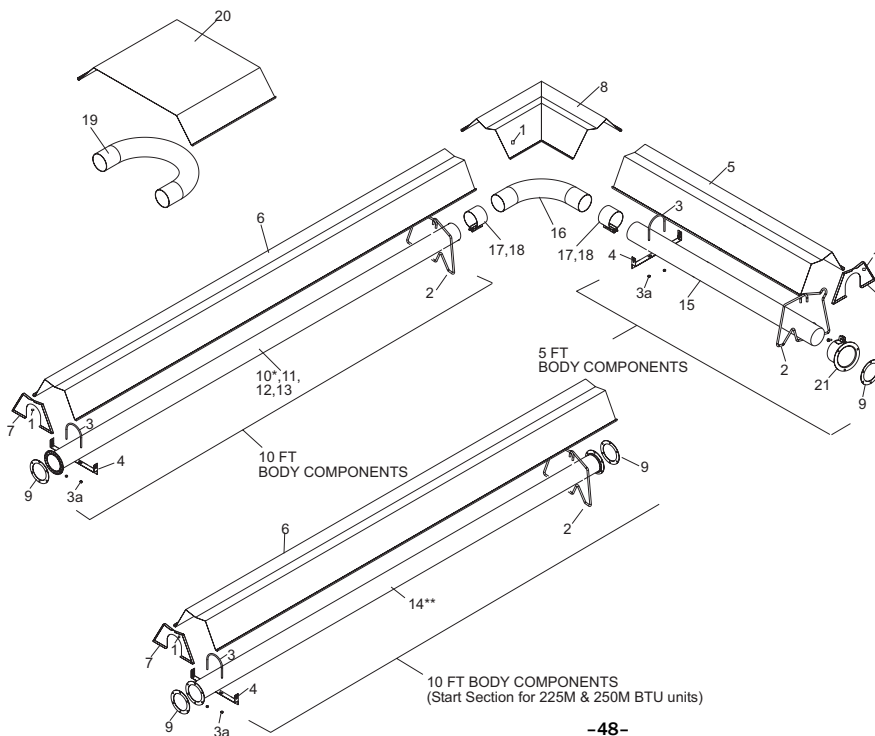

ALL ILLUSTRATIONS ARE INTENDED TO GIVE THE GENERAL IMPRESSION OF UNITS ONLY. OTHER COMBINATIONS OF 5 FT. AND 10 FT. SECTIONS, AND ONES WITH OR WITHOUT THE ELBOW PACKAGE ARE POSSIBLE. PLEASE CONSULT WITH YOUR SPACE-RAY SALES REPRESENTATIVE. WE RESERVE THE RIGHT TO ALTER ANY SPECIFICATION WITHOUT NOTICE.